

Clays Ferry Bridge Closure Detour Study  
Madison, Jessamine & Fayette Counties  
Item No 7-264

# Phase 2 Traffic Forecast Report

---



July 2024

**TABLE OF CONTENTS**

1.0 PROJECT DESCRIPTION..... 1

2.0 DATA COLLECTION EFFORTS ..... 3

3.0 FUTURE YEAR TRAFFIC ..... 3

    3.1 Historic Count Growth..... 3

    3.2 Kentucky State Data Center Projections ..... 4

    3.3 No-Build Model Results ..... 6

    3.4 Build Detour Results ..... 6

    3.5 Interchange Forecasts ..... 7

**FIGURES**

Figure 1: Phase 2 Build Concepts ..... 2

Figure 2: Adjacent Bridges Detail..... 3

Figure 3: Historic Interstate 75 Counts ..... 4

Figure 4: KSDC Fayette County Population Forecasts..... 5

Figure 5: KSDC Jessamine County Population Forecasts ..... 5

Figure 6: KSDC Madison County Population Forecasts..... 6

**TABLES**

Table 1: Existing Highway Volumes following Build Corridors..... 7

**APPENDICES**

- Appendix A: Estimated Turning Movement Counts
- Appendix B: 2045 No-Build - Bridge Open Turning Movement Forecasts
- Appendix C: 2045 No-Build - Bridge Closed Turning Movement Forecasts
- Appendix D: 2045 Build Southern Connector - Bridge Closed Turning Movement Forecasts
- Appendix E: 2045 Build Central Connector - Bridge Closed Turning Movement Forecasts
- Appendix F: 2045 Build Adjacent Bridge - Bridge Closed Turning Movement Forecasts

## 1.0 PROJECT DESCRIPTION

The Kentucky Transportation Cabinet (KYTC) initiated a planning study in fall 2022 to develop an operational detour plan in the event of a long-term closure of the Clays Ferry Bridge, carrying I-75 over the Kentucky River between Madison and Fayette counties. The study was conducted in two phases:

- Phase 1, present day detour options, optimizing operations within the existing network in the event of an unplanned closure
- Phase 2, representative new alignments for a new river crossing in the future

This traffic forecast report will focus on Phase 2 of the study. Phase 2 concentrated on new river crossings in three general areas.

Unless otherwise noted, two typical sections were considered for comparison purposes: 1) 11-foot lanes with 4-foot paved shoulders and 2) 44 feet of full-depth pavement, which could be striped for two to four travel lanes. A 45-mph design speed is assumed.

*Adjacent Bridges.* Three Build concepts run alongside the existing I-75 Clays Ferry Bridge, as this represents the shortest path and most direct link for detour traffic. New Bridge West (yellow in **Figure 1** and **Figure 2**) and New Bridge East (white) stretch between I-75 Exits 97 and 99, west and east of the existing alignment, respectively. The MOT Half Bridge concept creates a new, free-standing three-lane structure just west of the existing bridge with transitions and removable barrier at either end of the existing Clays Ferry Bridge, intended to maintain three lanes of traffic in each direction at 55+ mph should one half of the existing interstate facility be closed.

*Central Build Options.* A second set of Build concepts stretches between the I-75/KY 627 interchange (Exit 95) and the Fayette/Jessamine county boundary. Shown in cyan in **Figure 1**, Jacks Creek North is 11.3 miles long, running along sections of KY 3055 (White Hall Shrine Road), KY 1976 (Jacks Creek Pike), and KY 1974 (Tates Creek Road). Shown in pink, Valley View is 12.5 miles long and runs along sections of KY 3055 (White Hall Shrine Road), KY 1156 (Jacks Creek Road), and KY 1974 (Tates Creek Road).

*South Connector.* The Far South concept (green in **Figure 1**) lies near the Madison/Garrard county line and follows existing KY 39 and KY 595 for much of its length. End to end, the concept is 20.7 miles long.

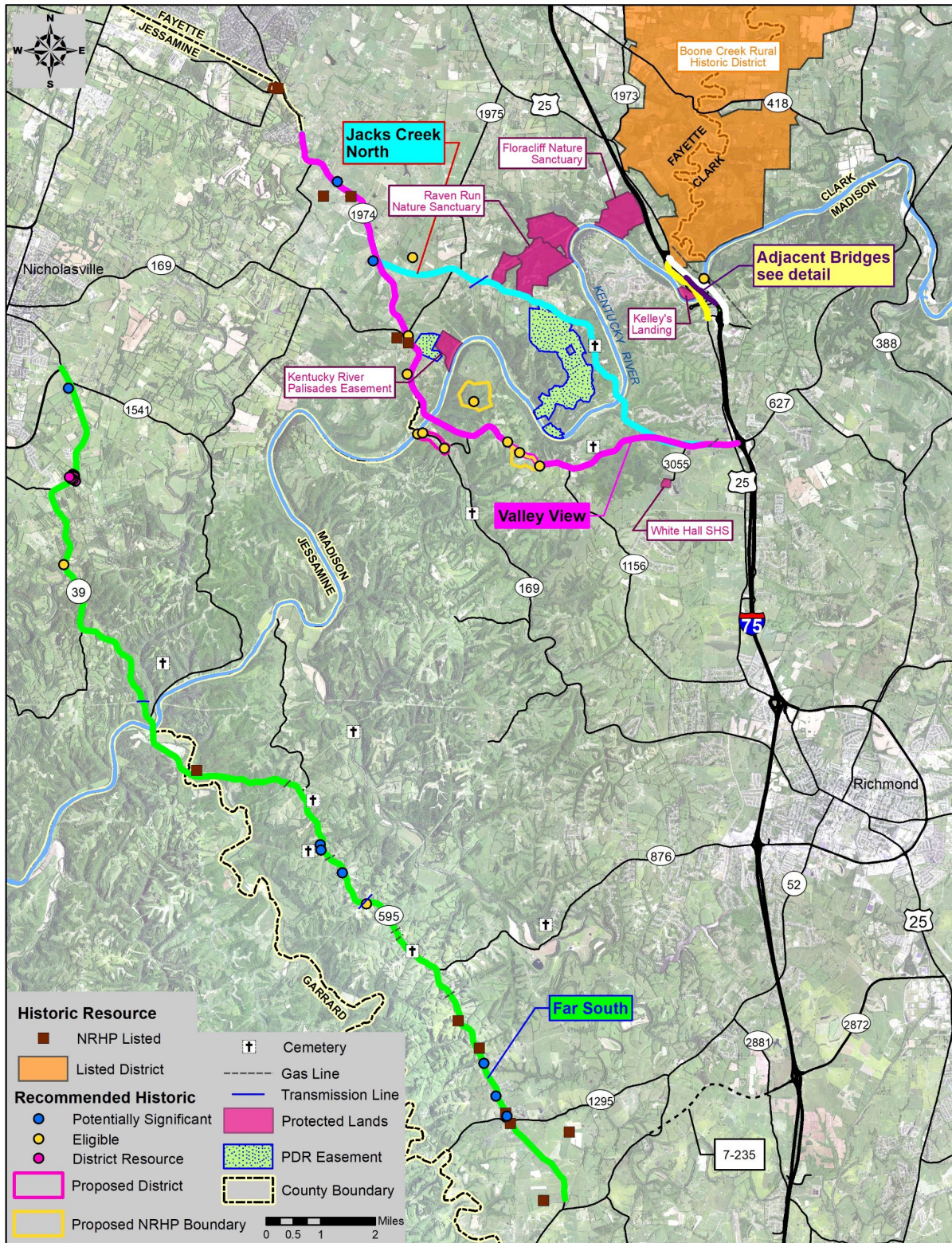

Figure 1: Phase 2 Build Concepts

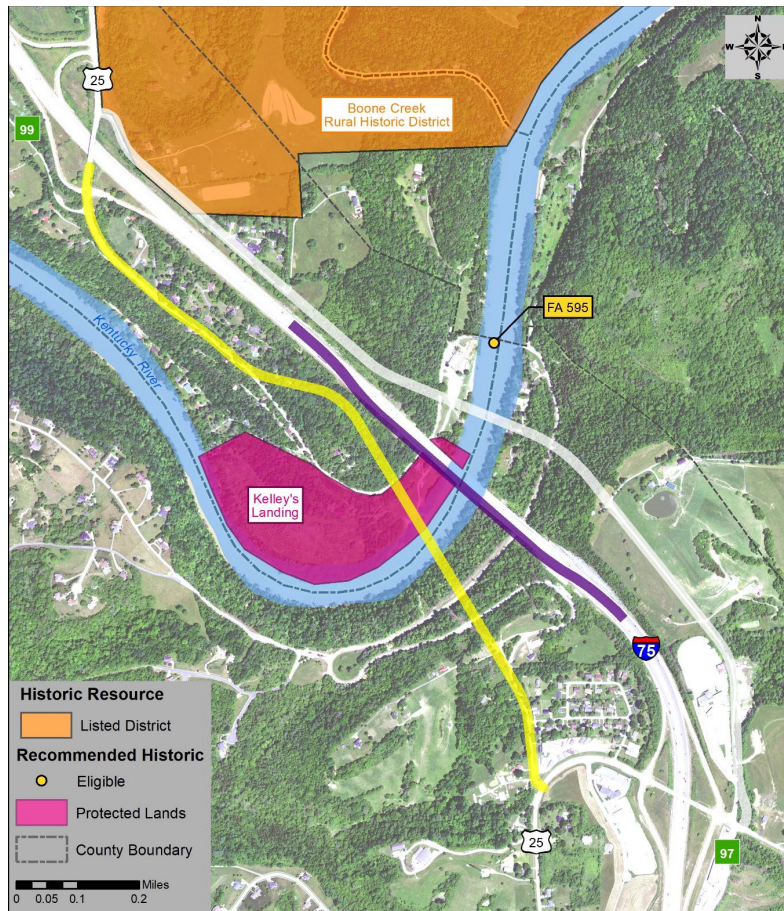

Figure 2: Adjacent Bridges Detail

## 2.0 DATA COLLECTION EFFORTS

No new counts were made for this project; instead unadjusted Streetlight-generated peak hour turning movement counts were used to estimate peak hour turning movement counts for ramp terminals at the following I-75 interchanges:

- Mile Point 83 – Duncannon Road
- Mile Point 95 – KY 627
- Mile Point 97 – US 25 (south)
- Mile Point 99 – US 25 (north) / US 421

Year 2023 base year turning movement diagrams are presented in **Appendix A**.

## 3.0 FUTURE YEAR TRAFFIC

### 3.1 Historic Count Growth

KYTC traffic counts for the section of I-75 that passes over the Clays Ferry Bridge are seen in **Figure 3** below. About 20% of this volume represents trucks. These counts show an annual growth rate of 0.84%.

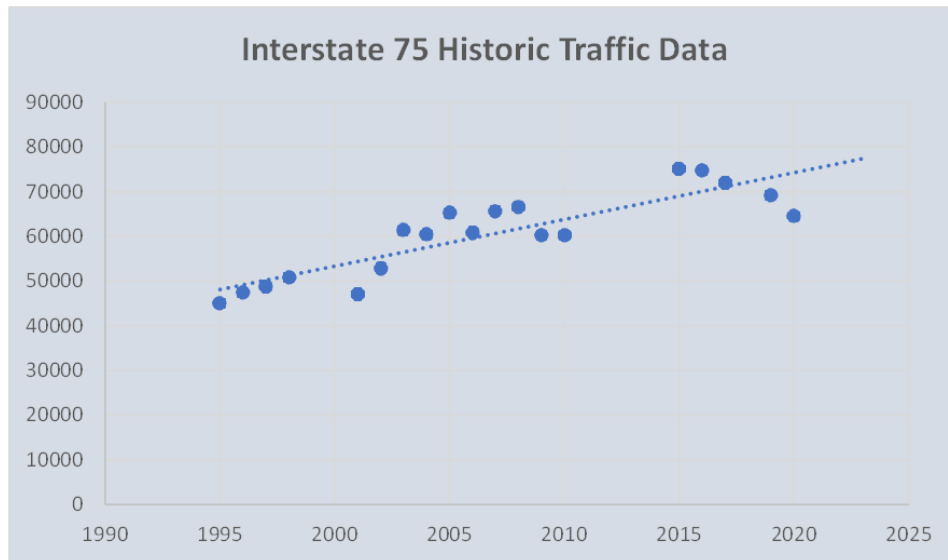

Figure 3: Historic Interstate 75 Counts

### 3.2 Kentucky State Data Center Projections

Projections from the Kentucky State Data Center show Fayette, Jessamine and Madison counties are expected to show positive growth through future year 2024. This data is summarized in **Figure 4** through **Figure 6**.

Figure 4: KSDC Fayette County Population Forecasts

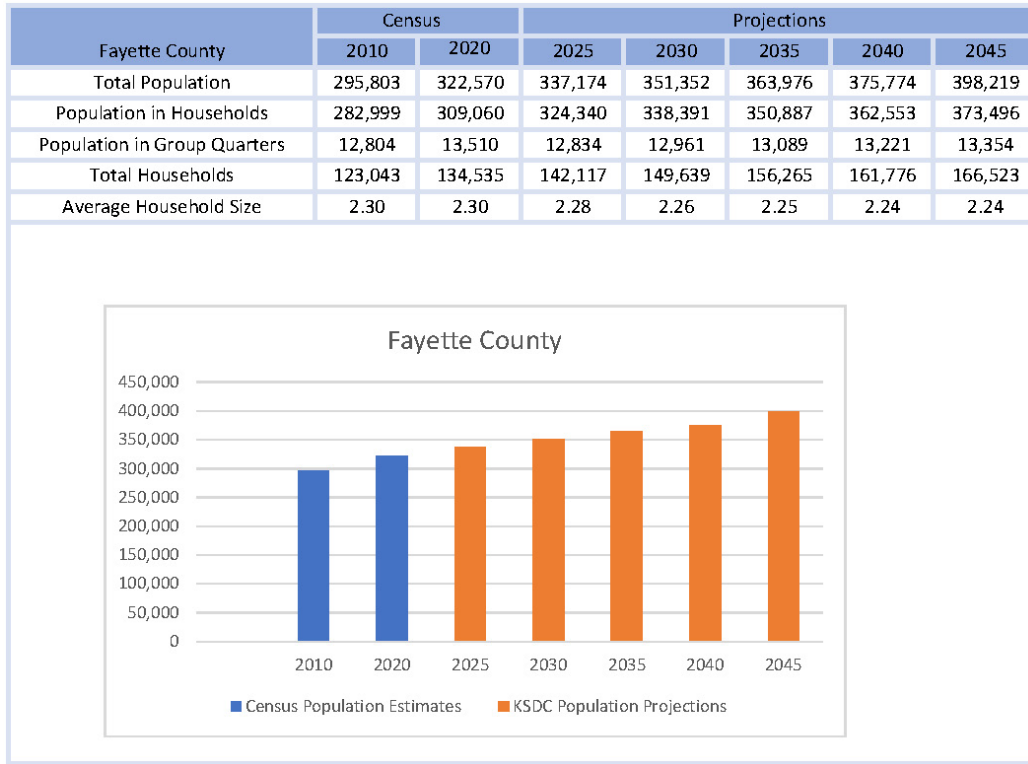

Figure 5: KSDC Jessamine County Population Forecasts

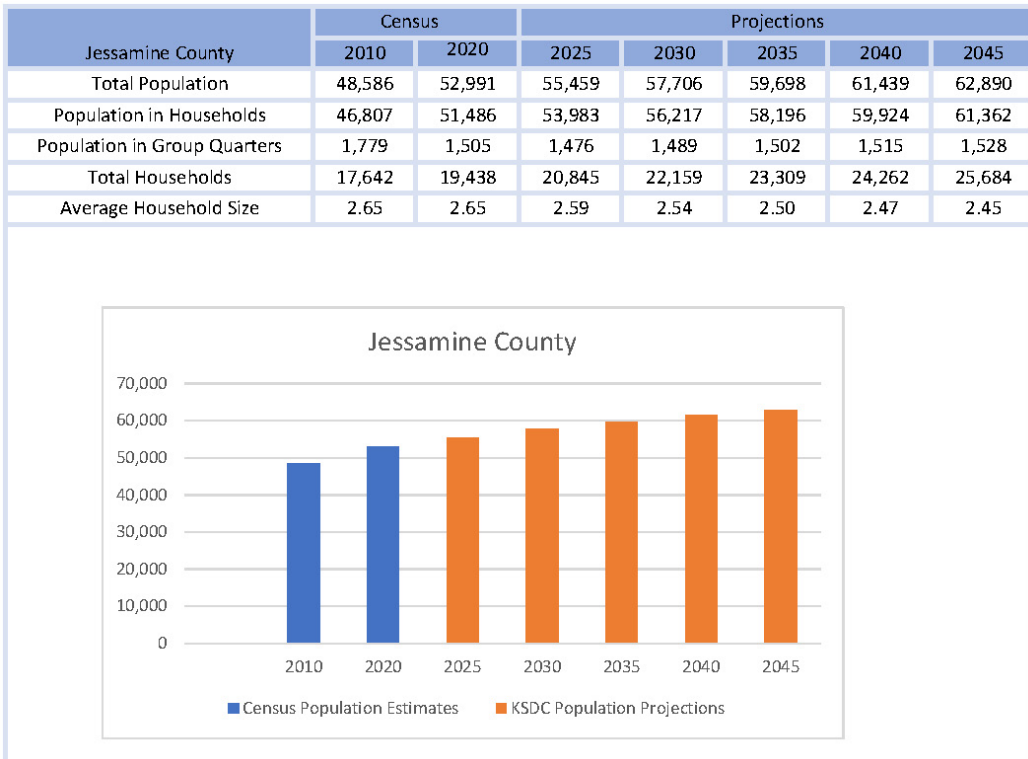
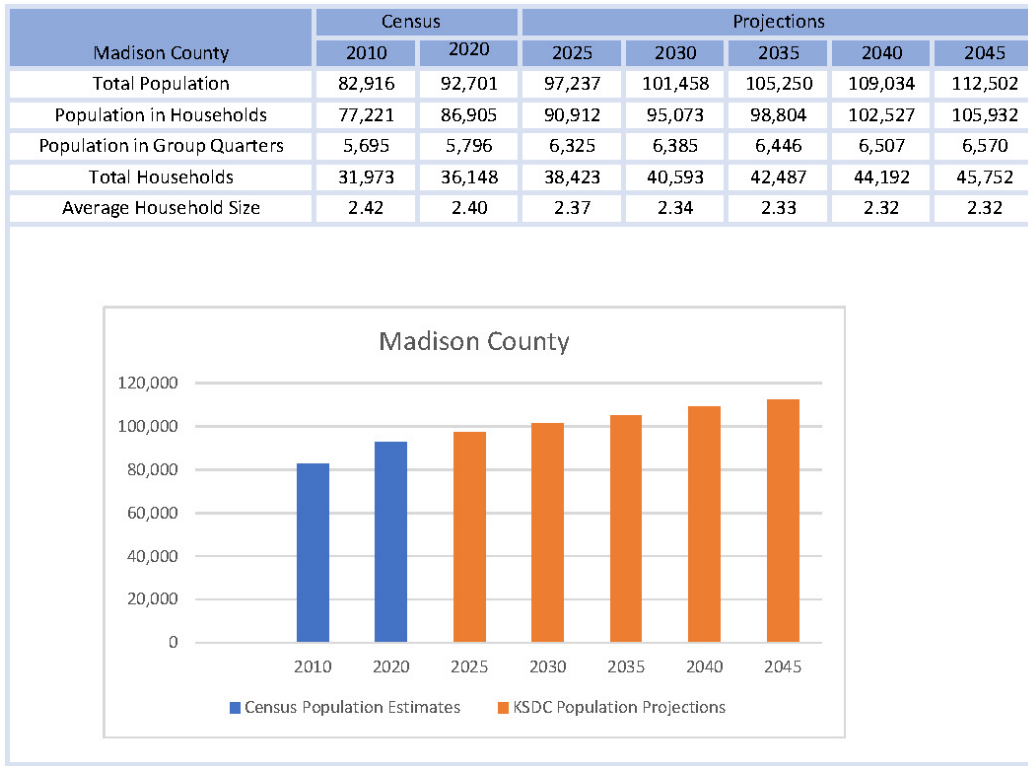

Figure 6: KSDC Madison County Population Forecasts



### 3.3 No-Build Model Results

The Lexington Area MPO “LAMPO” Travel Demand Model was used to estimate future year growth and diversion to proposed new Kentucky River crossings with and without the closure of the Clays Ferry Bridge. With the bridge open, No-Build model results showed an increase of 18.6% in vehicle miles traveled between model base year 2020 and future year 2045 over the 9-county model region. For comparison, model assignment across the Clays Ferry Bridge showed an increase of 20.7% between the same scenarios.

Considering these factors, a 0.8% annual growth rate was applied to the 2023 base year volume of 70,000 vehicles per day (vpd), resulting in 82,000 vpd projected to use the I-75 Clays Ferry Bridge in the 2045 No-Build scenario.

### 3.4 Build Detour Results

The LAMPO Model was used to estimate diversion for each of the three groups of Phase 2 Build concepts. The most recent KYTC count volumes on highway segments overlapping each Build corridor are presented in **Table 1** for reference.



Table 1: Existing Highway Volumes following Build Corridors

<i>Route</i>	<i>County</i>	<i>Approx. MP</i>	<i>ADT</i>	<i>% Trucks</i>
<i>KY 2328</i>	<i>Fayette</i>	<i>0.0-1.1</i>	<i>1,700</i>	<i>-</i>
<i>KY 3055</i>	<i>Madison</i>	<i>0.0-1.6</i>	<i>370</i>	<i>-</i>
<i>KY 1976</i>	<i>Fayette</i>	<i>0.0-1.4</i>	<i>420</i>	<i>-</i>
<i>KY 1974</i>	<i>Fayette</i>	<i>0.0-1.7</i>	<i>860</i>	<i>-</i>
<i>KY 1974</i>	<i>Fayette</i>	<i>1.7-4.2</i>	<i>1,300</i>	<i>6.4%</i>
<i>KY 1974</i>	<i>Fayette</i>	<i>4.2-5.5</i>	<i>6,400</i>	<i>6.4%</i>
<i>KY 1156</i>	<i>Madison</i>	<i>6.3-9.4</i>	<i>270</i>	<i>-</i>
<i>KY 169</i>	<i>Jessamine</i>	<i>0.0-2.0</i>	<i>530</i>	<i>7.9%</i>
<i>KY 595</i>	<i>Madison</i>	<i>10.8-12.8</i>	<i>370</i>	<i>-</i>
<i>KY 595</i>	<i>Madison</i>	<i>12.8-14.0</i>	<i>740</i>	<i>-</i>
<i>KY 595</i>	<i>Madison</i>	<i>14.0-16.1</i>	<i>360</i>	<i>-</i>
<i>KY 595</i>	<i>Madison</i>	<i>16.1-17.1</i>	<i>850</i>	<i>-</i>
<i>KY 595</i>	<i>Madison</i>	<i>17.1-22.3</i>	<i>550</i>	<i>-</i>
<i>KY 39</i>	<i>Jessamine</i>	<i>0.0-2.4</i>	<i>390</i>	<i>-</i>
<i>KY 39</i>	<i>Jessamine</i>	<i>2.4-5.2</i>	<i>1,000</i>	<i>-</i>

*Adjacent Bridges.* With I-75 open to normal traffic, New Bridge East or West would carry minimal traffic in 2045: around 2,000 vpd as the existing interstate provides a more direct, higher speed connection. With the I-75 Clays Ferry Bridge closed, either Adjacent Bridge corridor is constrained by its assumed capacity—up to 25,000 vpd with two lanes or up to 40,000 vpd with four lanes.

*Central Build Options.* With I-75 open to normal traffic, either Central Build corridor would carry an estimated 14,500 vpd based on land use and development patterns in the regional model. Currently these routes carry minimal traffic: less than 500 vpd south of the ferry crossing and less than 1,000 vpd north of the ferry. The new link also diverts some traffic from congested facilities: 8,000 vpd shifting from the I-75 Clays Ferry Bridge to the new route and 6,000 vpd from Man O War Boulevard near Hamburg. With the I-75 closed, either corridor is constrained by its assumed capacity—up to 25,000 vpd with two lanes or up to 40,000 vpd with four lanes.

*South Connector.* The model projects up to 6,100 vpd using the new route with I-75 open with minimal traffic diverted from the Clays Ferry Bridge. With the bridge closed to traffic 11,400 vpd would be drawn to this route.

### 3.5 Interchange Forecasts

Interchange forecasts were prepared for the following ramps; mainline I-75 thru volumes are not presented in the spreadsheets:

- Mile Point 83 – Duncannon Road
- Mile Point 95 – KY 627
- Mile Point 97 – US 25 (south)
- Mile Point 99 – US 25 (north) / US 421

Bridge closed turning movements were determined from either model assignment where detour routes were under capacity or by the capacity of the detour facility. Forecasts assume a two-lane Build corridor, capping daily capacity at 25,000 vpd. Hourly and directional distributions were applied from existing traffic patterns on Clays Ferry Bridge: skewing northbound in the morning and southbound in the afternoon with peak hour volumes of 3,500 vehicles per hour (vph) AM and 4,000 vph PM.

No-Build / Bridge Open turning movement forecasts are included in **Appendix B**.

No-Build / Bridge Closed turning movement forecasts are included in **Appendix C**.

Far South Connector / Bridge Closed turning movement forecasts are included in **Appendix D**.

Central Connector / Bridge Closed turning movement forecasts are included in **Appendix E**. These correspond to both the Jacks Creek North and Valley View Build options.

Adjacent Bridge / Bridge Closed turning movement forecasts are included in **Appendix F**, corresponding to all three Adjacent Bridge Build options.

# APPENDIX A

EXISTING ESTIMATED TURNING MOVEMENT FORECASTS

PROJECT: Clays Ferry Bridge Closure  
 ITEM NUMBER: 0  
 MARS NUMBER: 0  
 REQUEST DATE: Saturday, January 0, 1900  
 ANALYST: 0  
 YEAR: 2023 ADT and Design Hour Volumes  
 INTERSECTION: I75 & Duncannon Interchange

## 2023 EXISTING

### TURN MOVEMENT 1 (2023)

**\*\*DHV TURN MOVEMENT FORECASTS SHOULD NOT BE USED FOR SIGNAL TIMING OR WARRANT ANALYSIS**

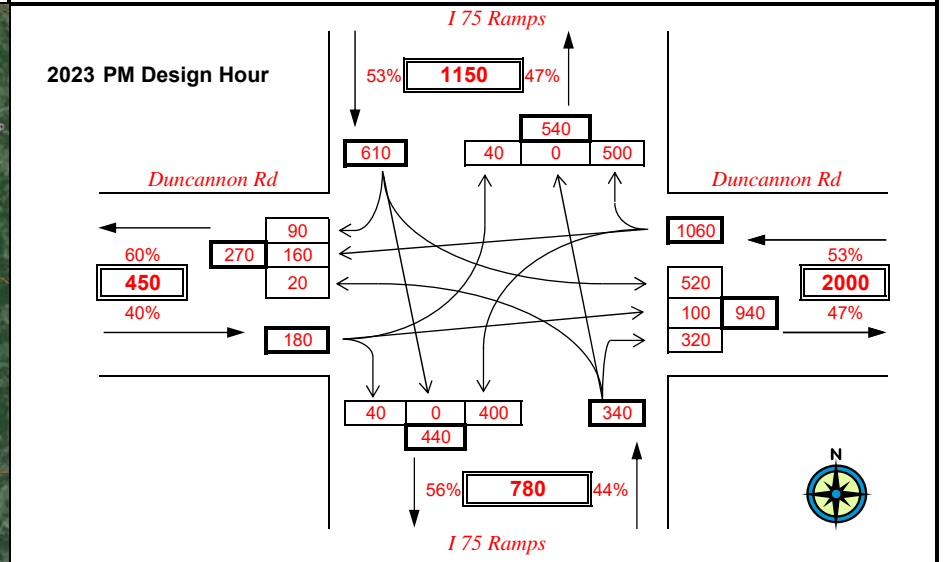
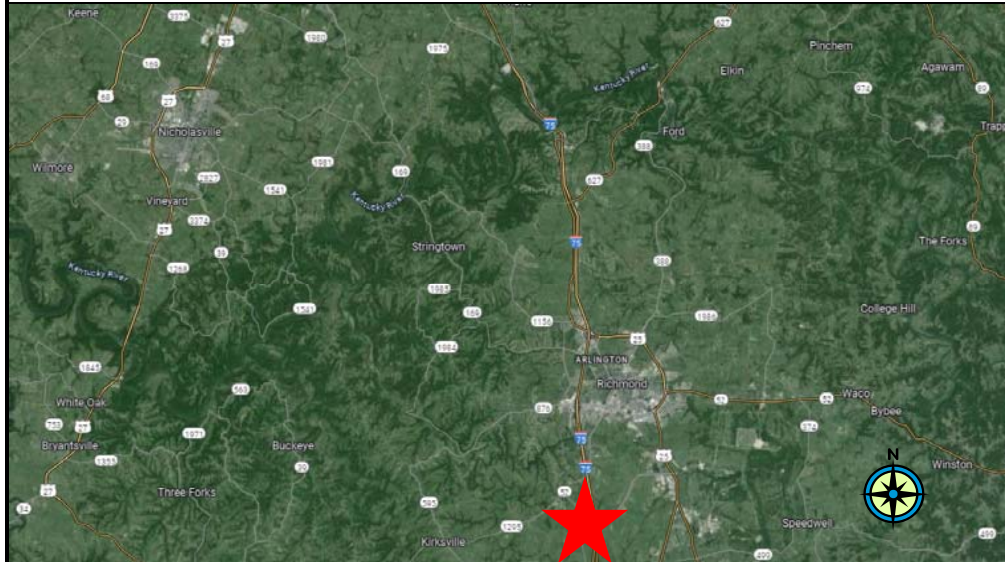
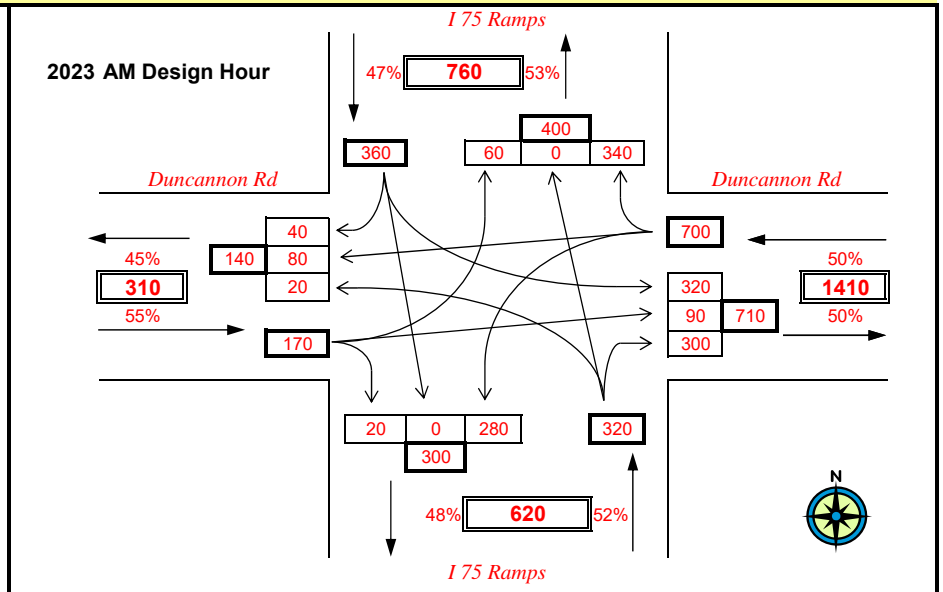
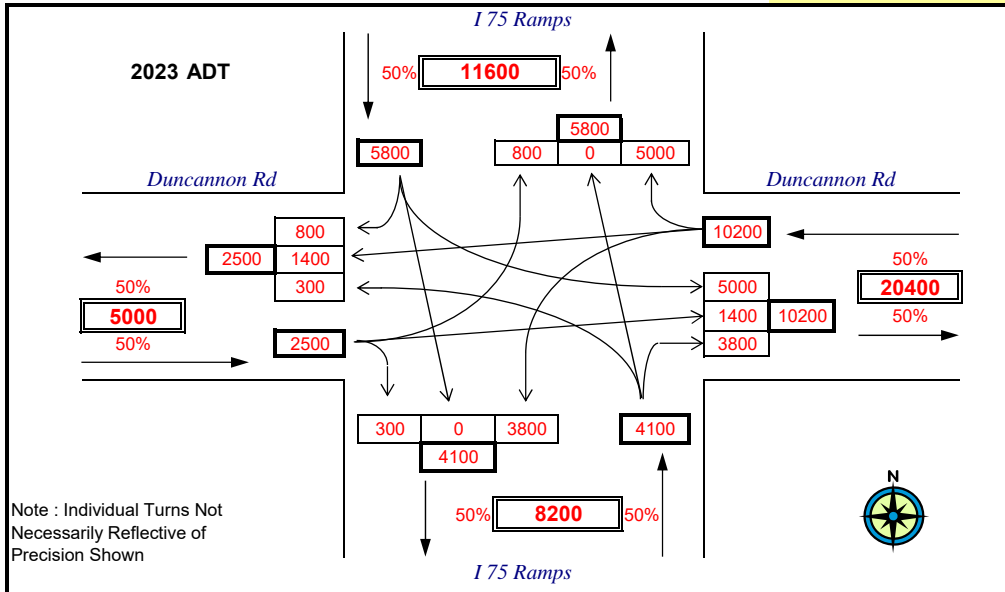

PROJECT: Clays Ferry Bridge Closure  
 ITEM NUMBER: 0  
 MARS NUMBER: 0  
 REQUEST DATE: Saturday, January 0, 1900  
 ANALYST: 0  
 YEAR: 2023 ADT and Design Hour Volumes  
 INTERSECTION: KY 627 & I 75 Ramps

## 2023 EXISTING

### TURN MOVEMENT 2 (2023)

**\*\*DHV TURN MOVEMENT FORECASTS SHOULD NOT BE USED FOR SIGNAL TIMING OR WARRANT ANALYSIS\*\***

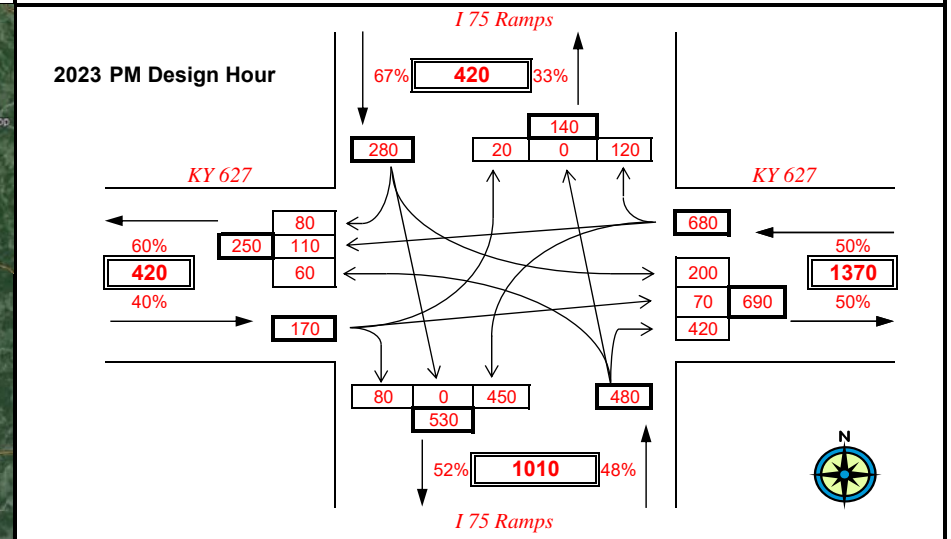
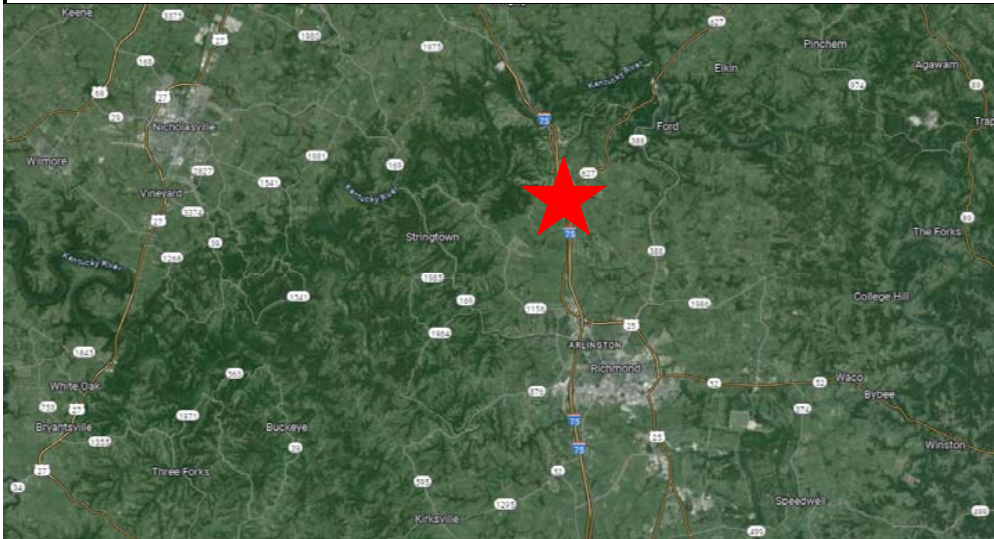
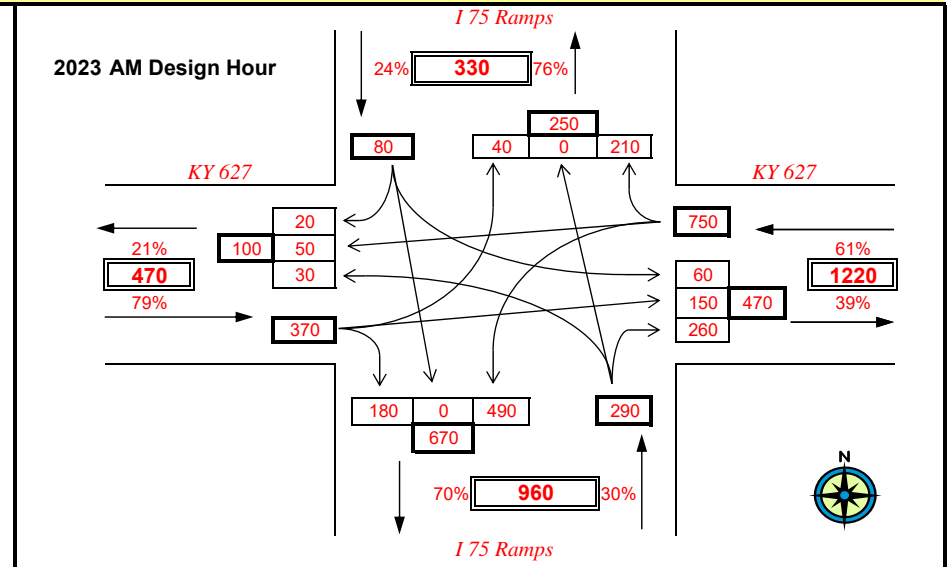
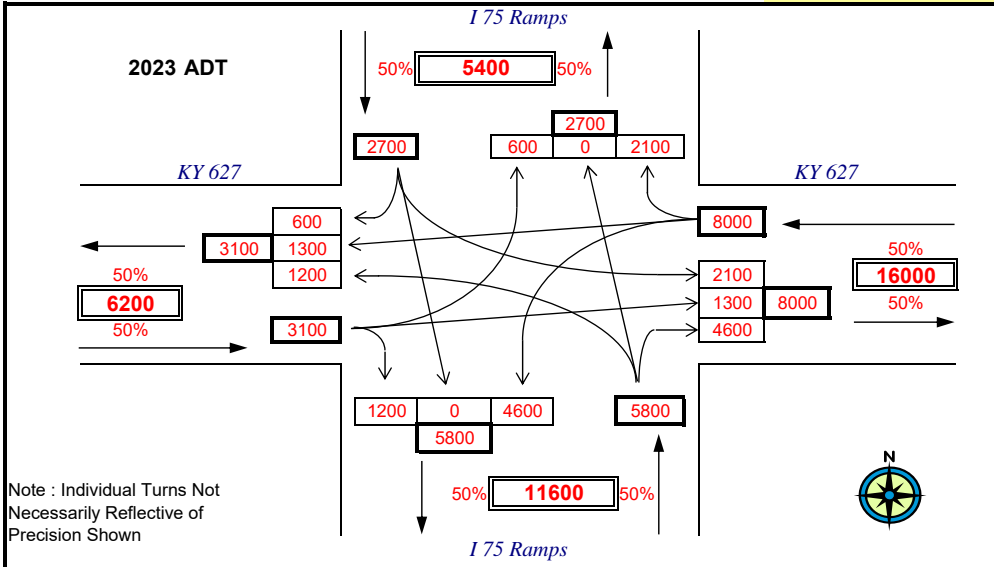

PROJECT: Clays Ferry Bridge Closure Phase 2  
 ITEM NUMBER: 0  
 MARS NUMBER: 0  
 REQUEST DATE: Saturday, January 0, 1900  
 ANALYST: 0  
 YEAR: 2023 ADT and Design Hour Volumes  
 INTERSECTION: I 75 Ramps & US 25

## 2023 EXISTING

### TURN MOVEMENT 3 (2023)

**\*\*DHV TURN MOVEMENT FORECASTS SHOULD NOT BE USED FOR SIGNAL TIMING OR WARRANT ANALYSIS**

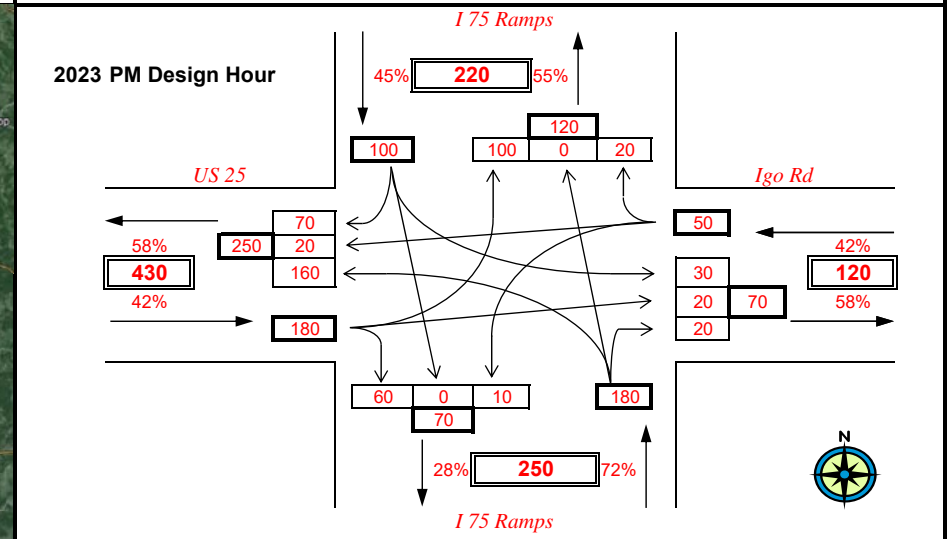
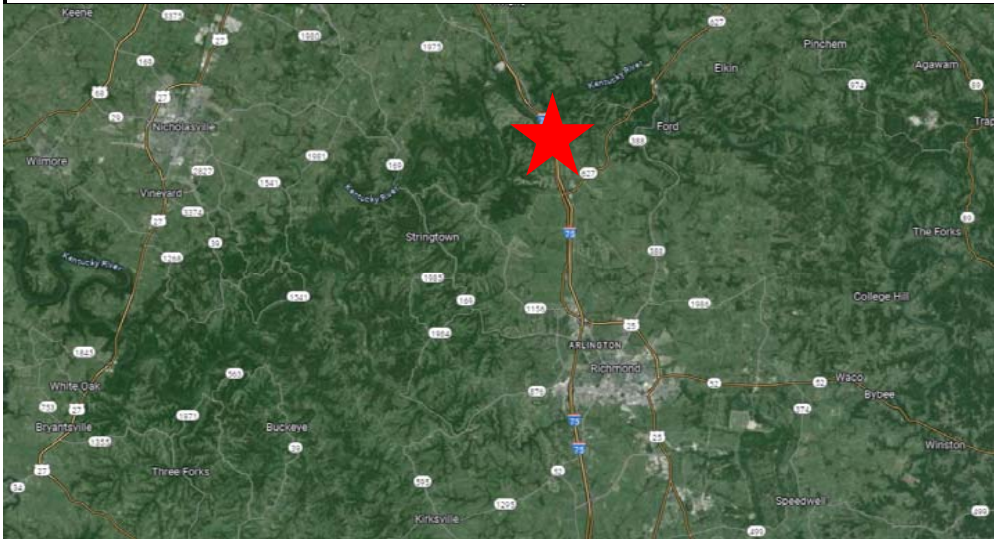
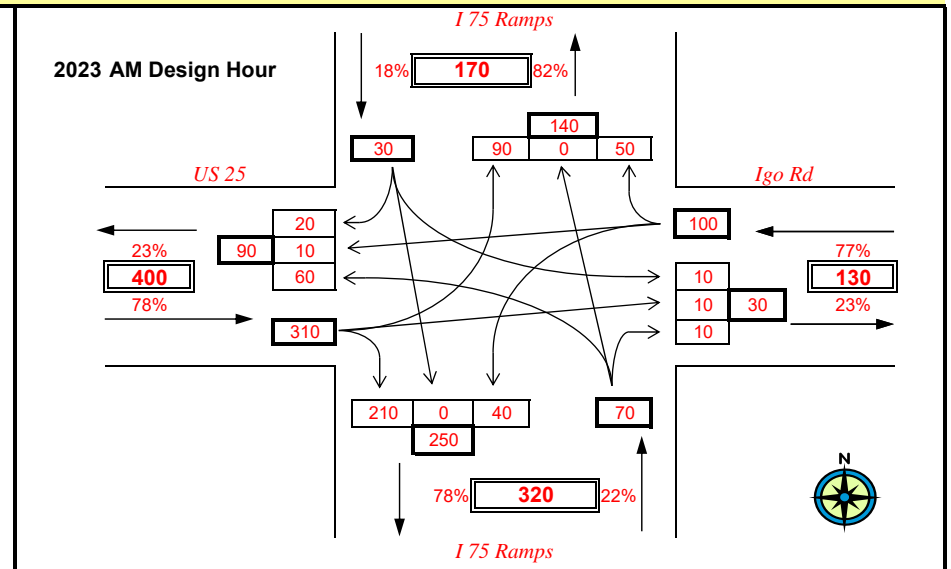
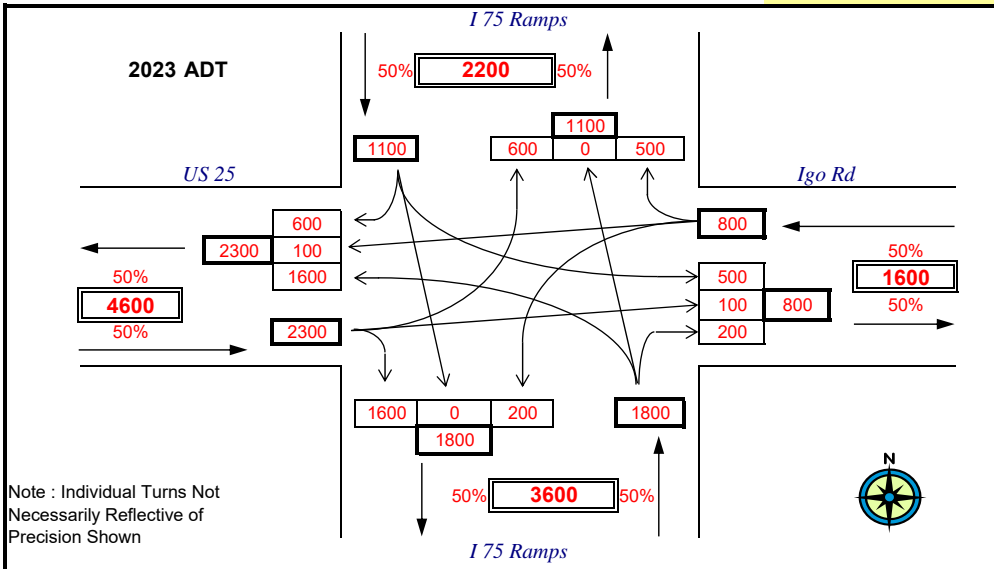

PROJECT: Clays Ferry Bridge Closure  
 ITEM NUMBER: 0  
 MARS NUMBER: 0  
 REQUEST DATE: Saturday, January 0, 1900  
 ANALYST: 0  
 YEAR: 2023 ADT and Design Hour Volumes  
 INTERSECTION: US 25 N & I 75 Ramps

## 2023 EXISTING

### TURN MOVEMENT 4 (2023)

**\*\*DHV TURN MOVEMENT FORECASTS SHOULD NOT BE USED FOR SIGNAL TIMING OR WARRANT ANALYSIS\*\***

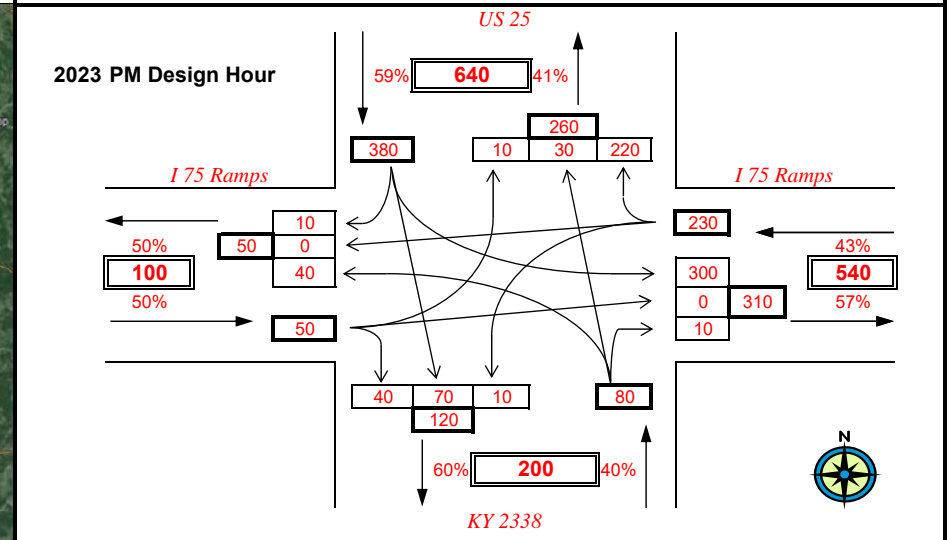
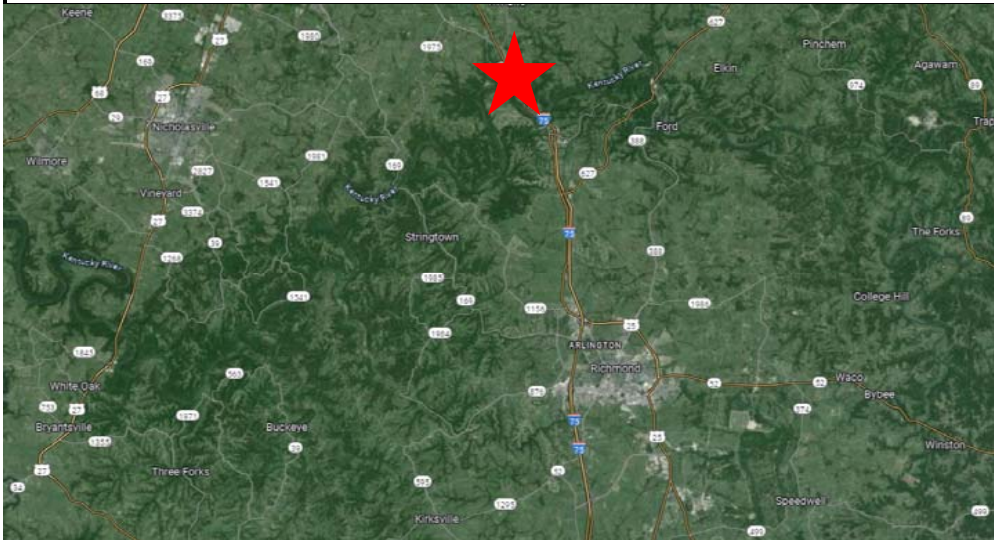
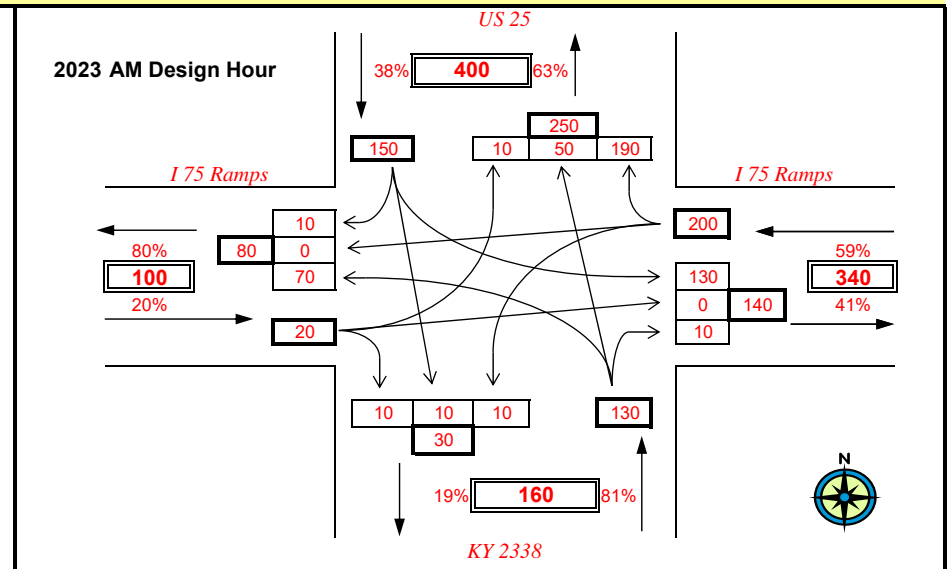
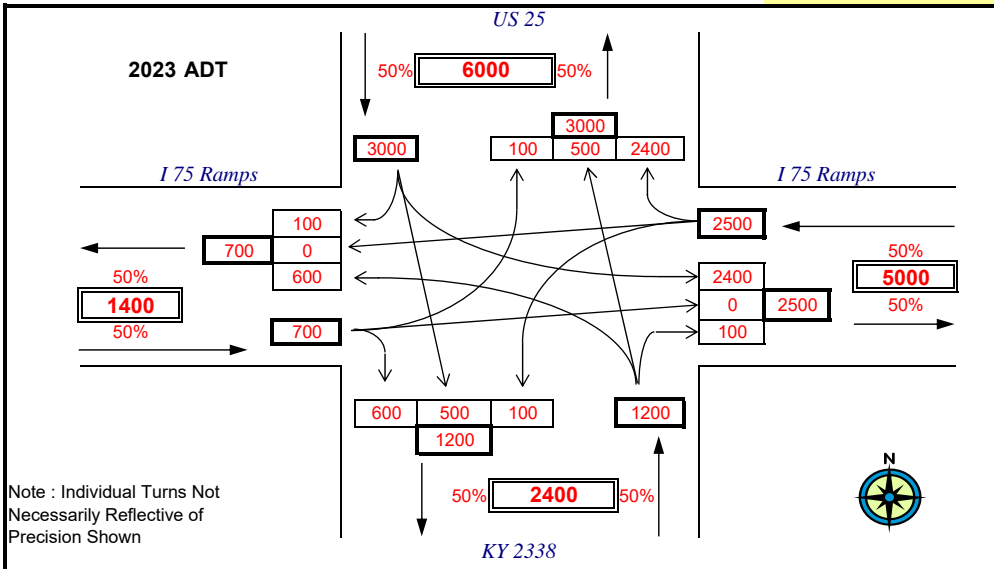

# APPENDIX B

NO BUILD – BRIDGE OPEN TURNING MOVEMENT  
FORECASTS



PROJECT: Clays Ferry Bridge Closure  
 ITEM NUMBER: 0  
 MARS NUMBER: 0  
 REQUEST DATE: Saturday, January 0, 1900  
 ANALYST: 0  
 YEAR: **2045** **ADT and Design Hour Volumes**  
 INTERSECTION: I75 & Duncannon Interchange

# 2045 NO BUILD BRIDGE OPEN

## TURN MOVEMENT 1 (2045)

**\*\*DHV TURN MOVEMENT FORECASTS SHOULD NOT BE USED FOR SIGNAL TIMING OR WARRANT ANALYSIS**

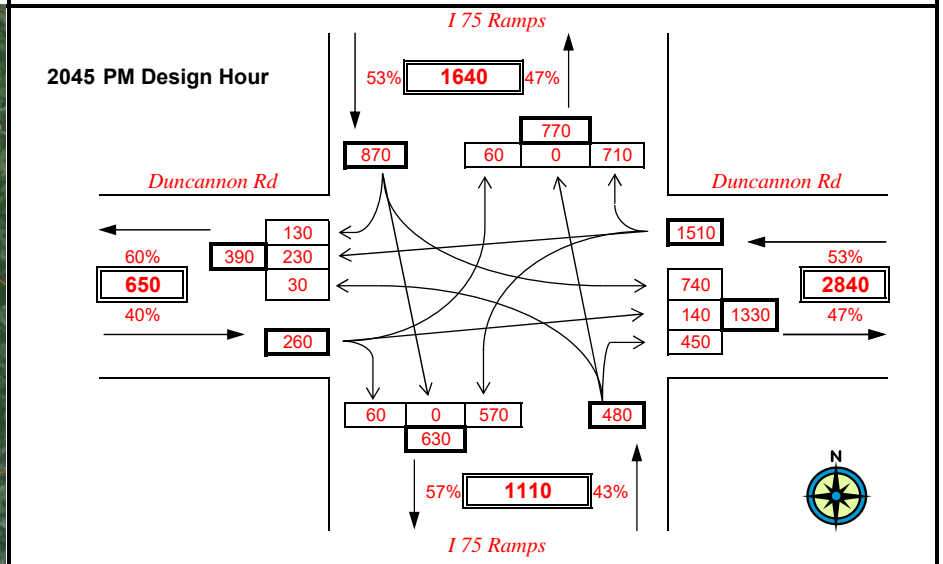
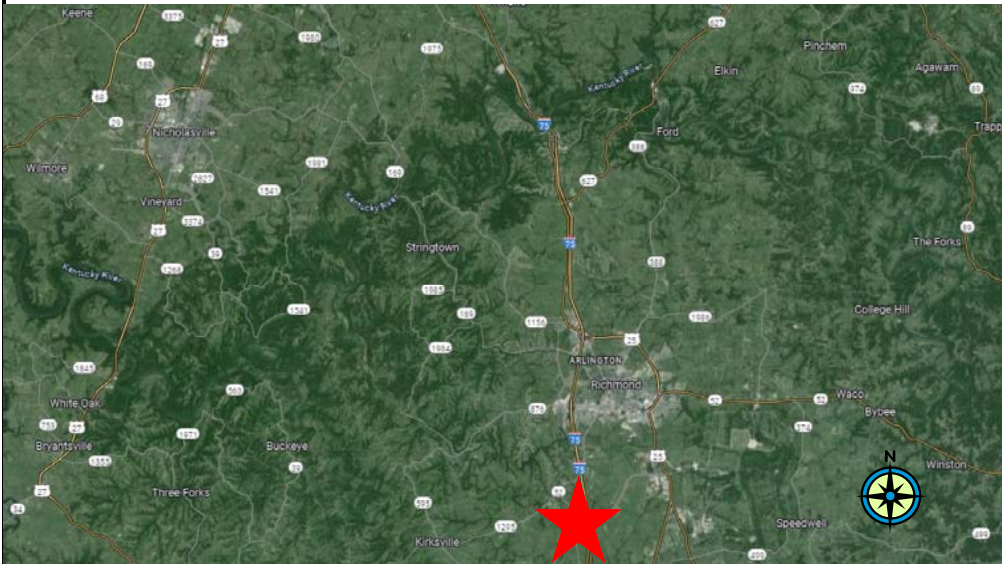
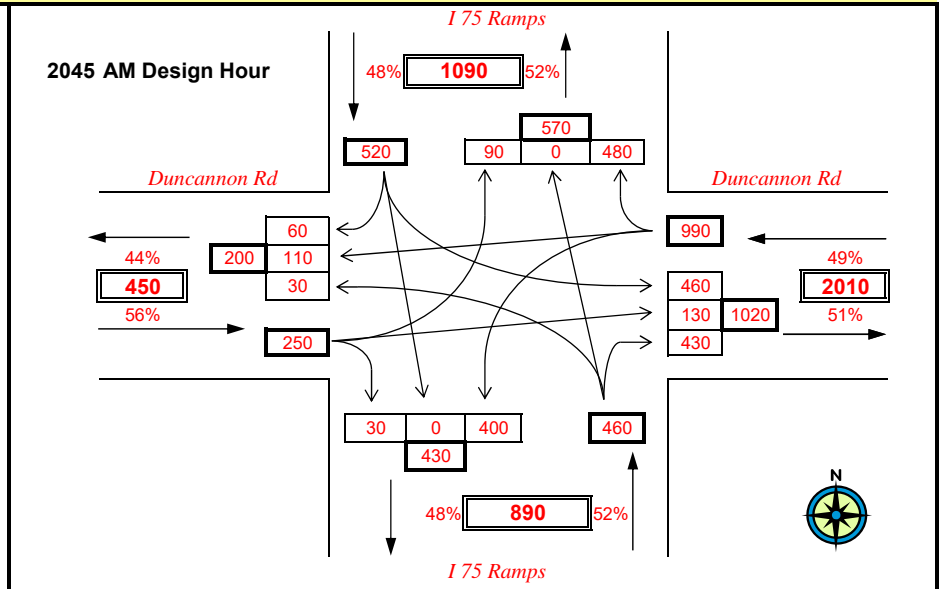
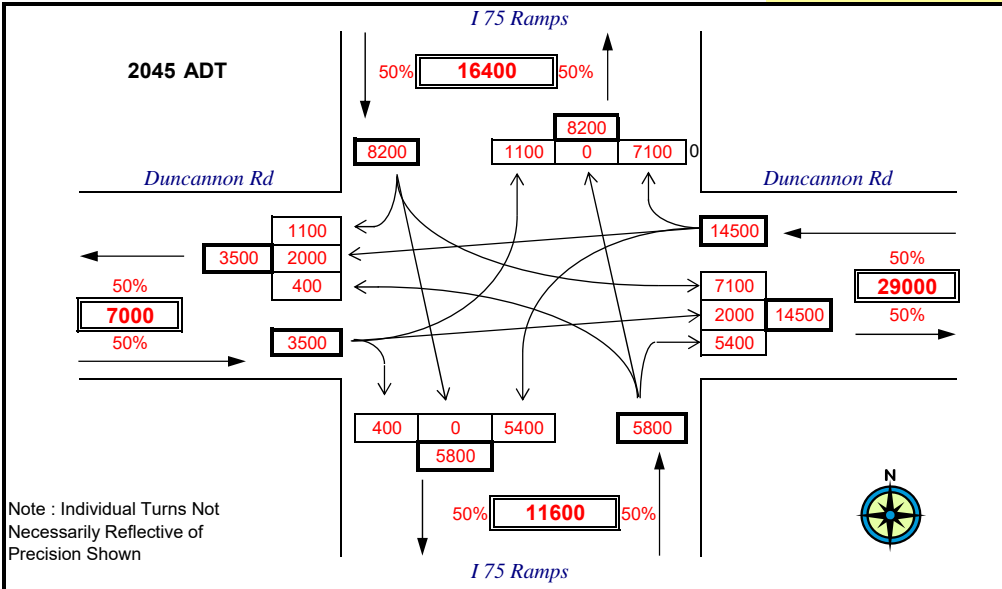

PROJECT: Clays Ferry Bridge Closure  
 ITEM NUMBER: 0  
 MARS NUMBER: 0  
 REQUEST DATE: Saturday, January 0, 1900  
 ANALYST: 0  
 YEAR: 2045 ADT and Design Hour Volumes  
 INTERSECTION: KY 627 & I 75 Ramps

## 2045 NO BUILD BRIDGE OPEN

### TURN MOVEMENT 2 (2045)

**\*\*DHV TURN MOVEMENT FORECASTS SHOULD NOT BE USED FOR SIGNAL TIMING OR WARRANT ANALYSIS**

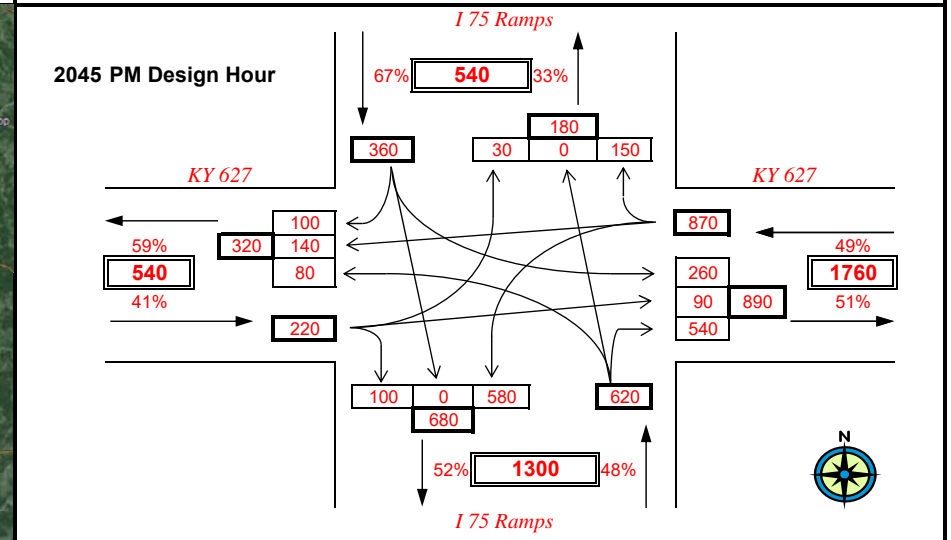
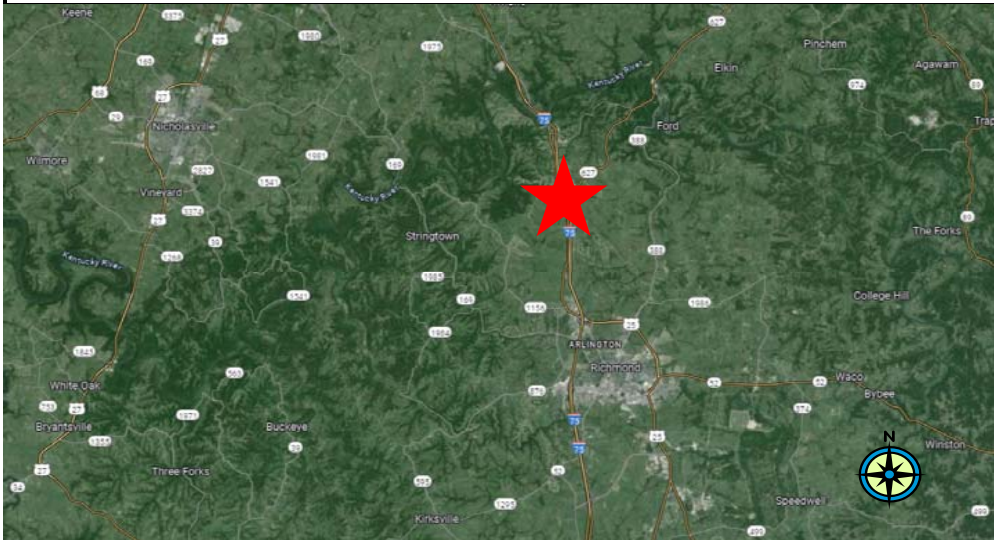
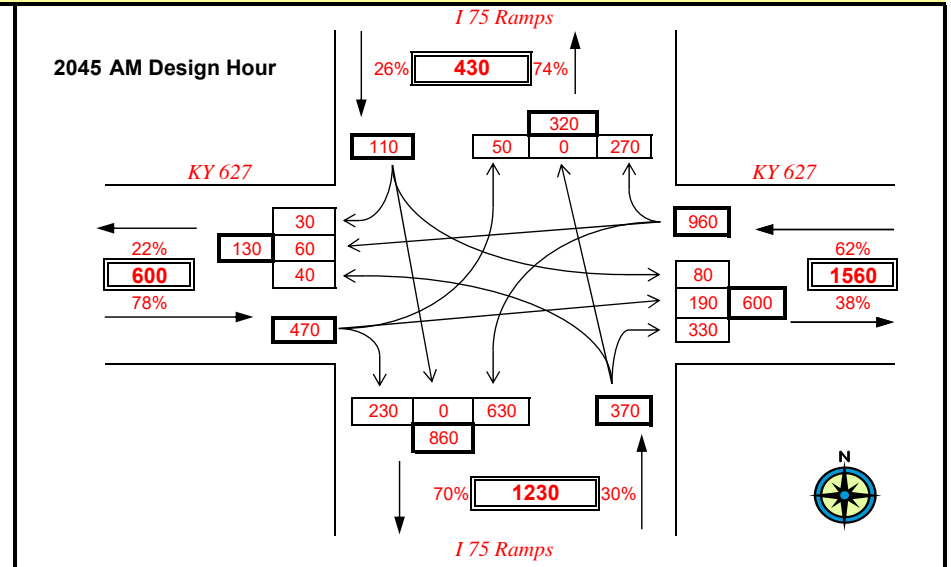
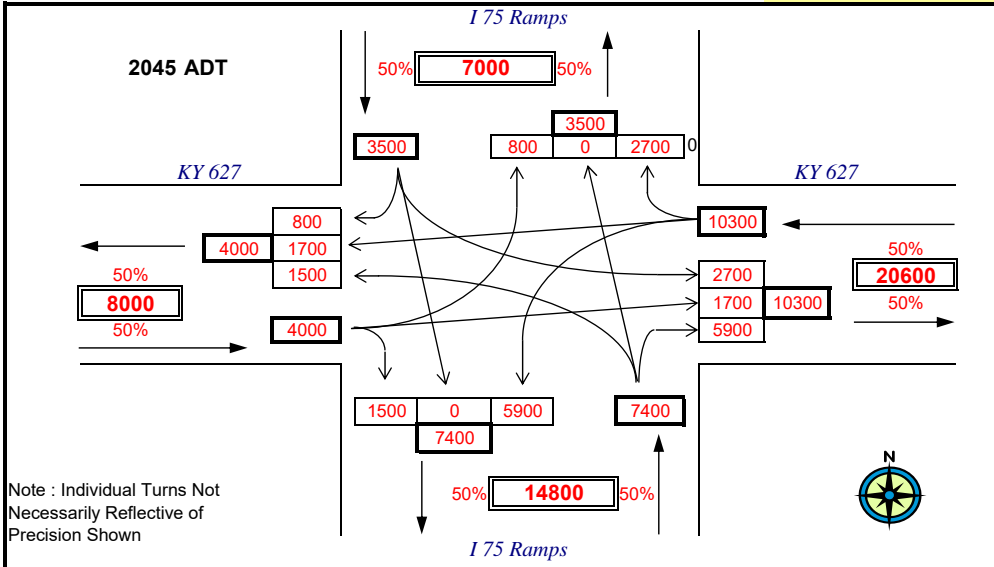

PROJECT: Clays Ferry Bridge Closure Phase 2  
 ITEM NUMBER: 0  
 MARS NUMBER: 0  
 REQUEST DATE: Saturday, January 0, 1900  
 ANALYST: 0  
 YEAR: 2045 ADT and Design Hour Volumes  
 INTERSECTION: I 75 Ramps & US 25

## 2045 NO BUILD BRIDGE OPEN

### TURN MOVEMENT 3 (2045)

**\*\*DHV TURN MOVEMENT FORECASTS SHOULD NOT BE USED FOR SIGNAL TIMING OR WARRANT ANALYSIS**

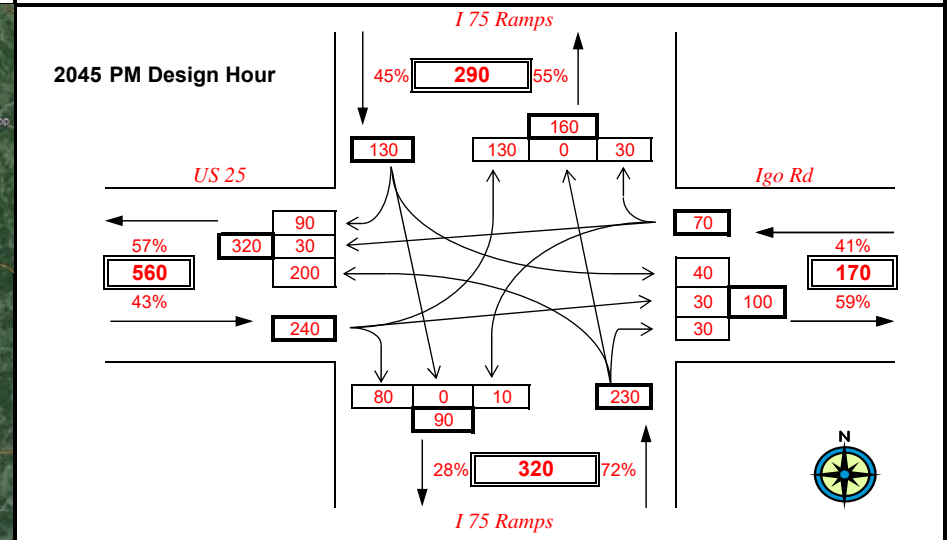
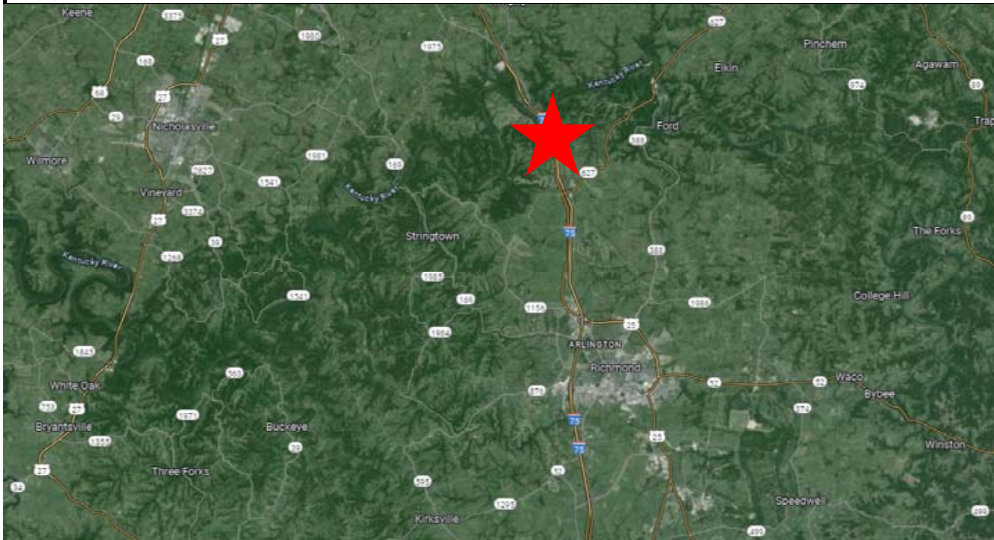
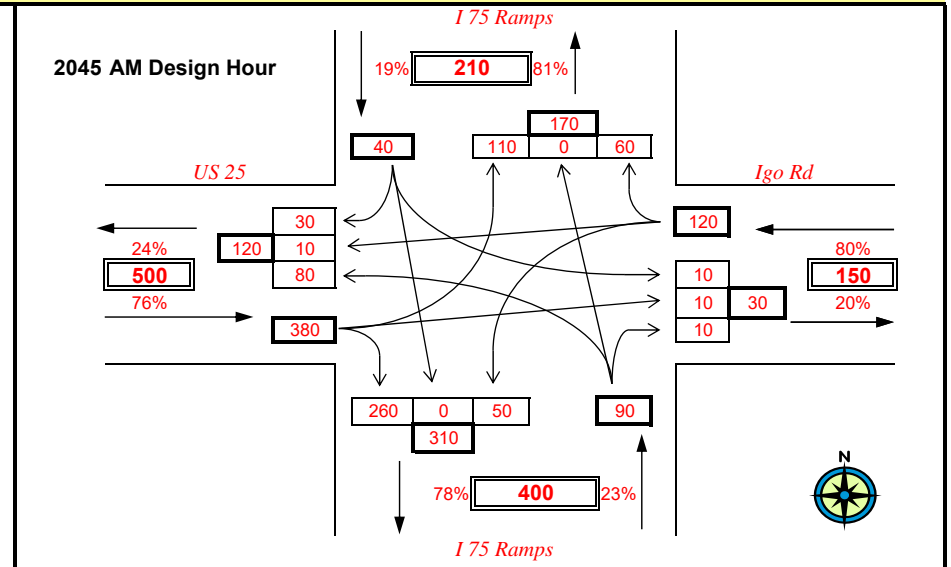
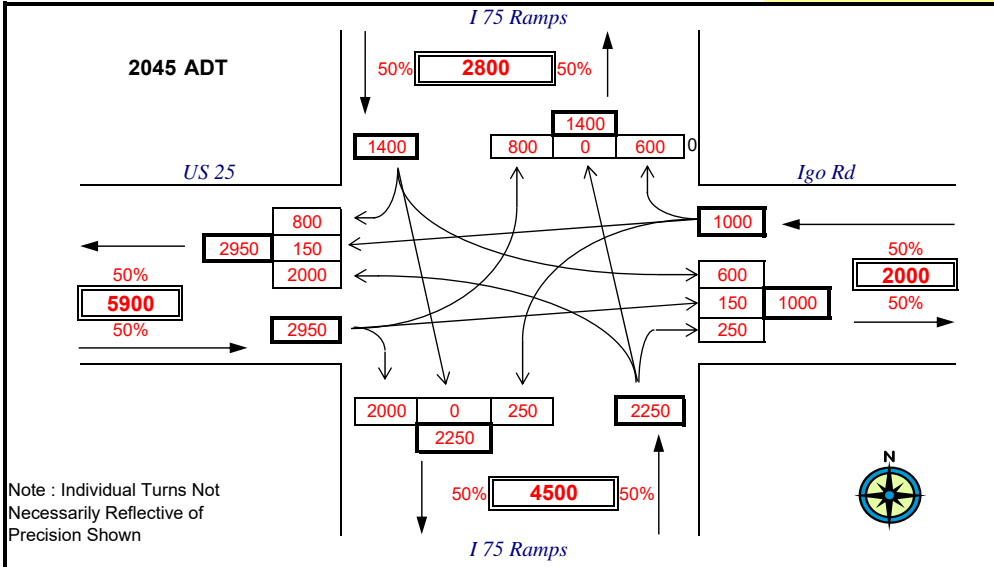

PROJECT: Clays Ferry Bridge Closure  
 ITEM NUMBER: 0  
 MARS NUMBER: 0  
 REQUEST DATE: Saturday, January 0, 1900  
 ANALYST: 0  
 YEAR: 2045 ADT and Design Hour Volumes  
 INTERSECTION: US 25 N & I 75 Ramps

## 2045 NO BUILD BRIDGE OPEN

### TURN MOVEMENT 4 (2045)

**\*\*DHV TURN MOVEMENT FORECASTS SHOULD NOT BE USED FOR SIGNAL TIMING OR WARRANT ANALYSIS\*\***

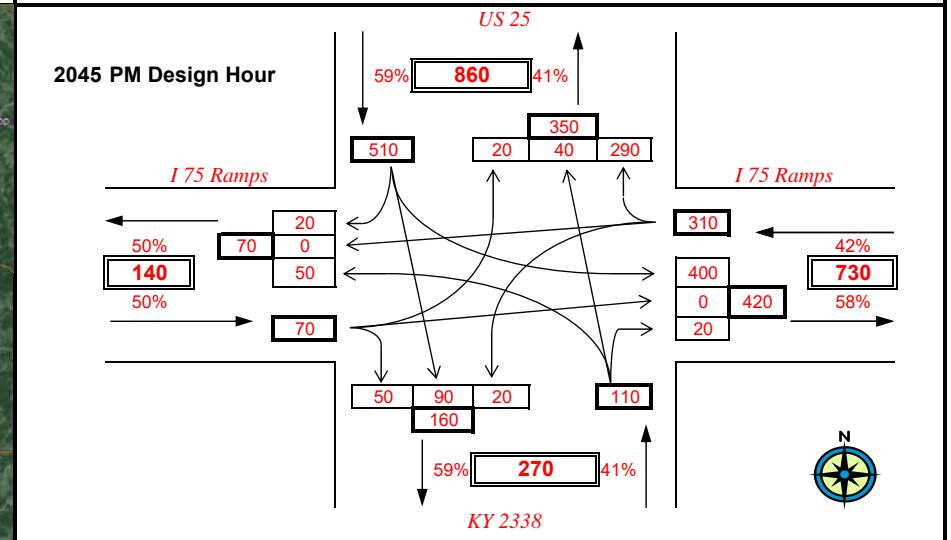
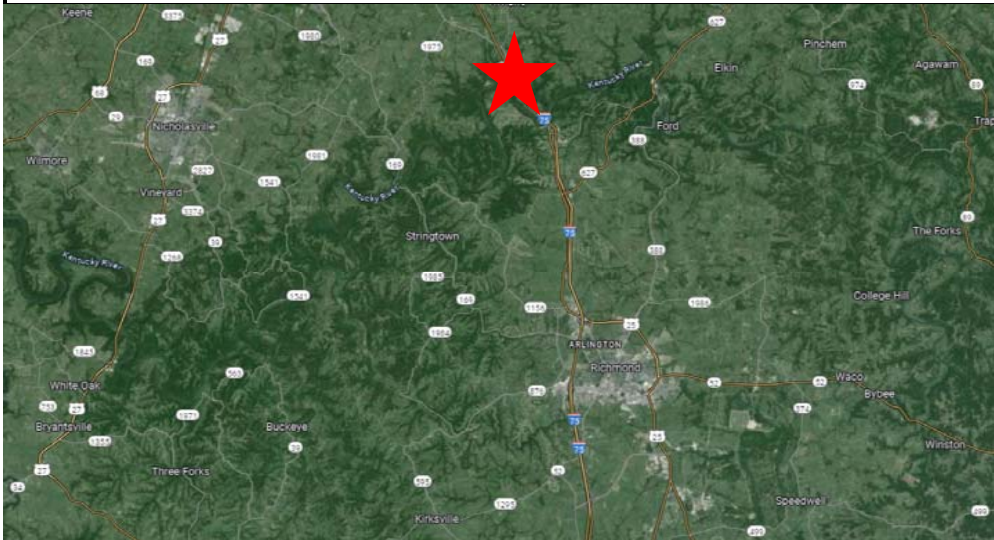
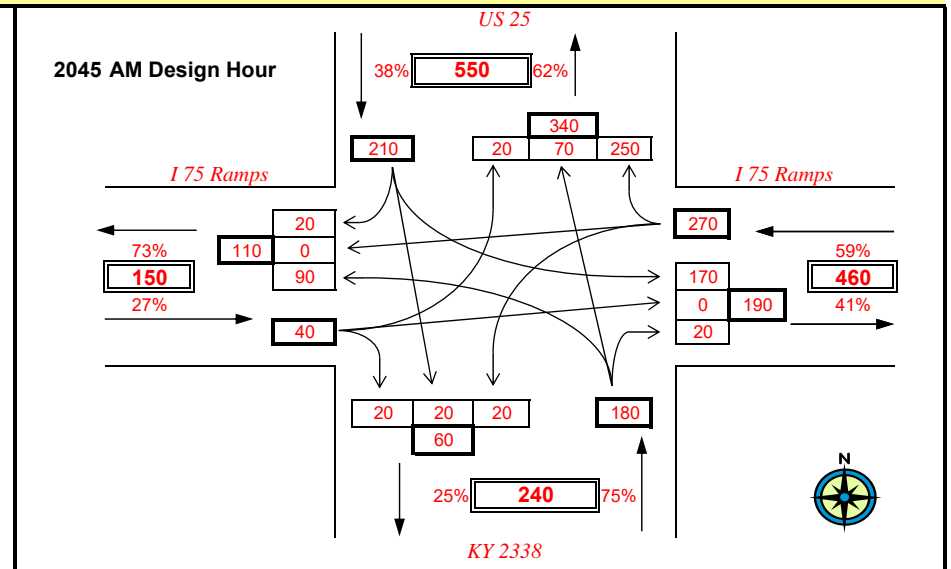
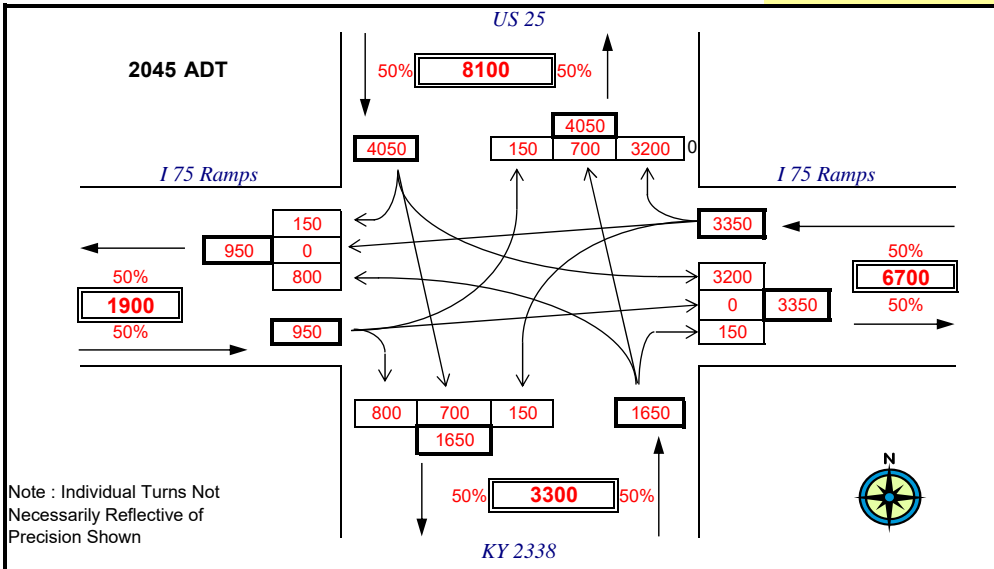

# APPENDIX C

NO BUILD – BRIDGE CLOSED TURNING MOVEMENT  
FORECASTS

PROJECT: Clays Ferry Bridge Closure  
 ITEM NUMBER: 0  
 MARS NUMBER: 0  
 REQUEST DATE: Saturday, January 0, 1900  
 ANALYST: 0  
 YEAR: **2045** ADT and Design Hour Volumes  
 INTERSECTION: I75 & Duncannon Interchange

## 2045 NO BUILD BRIDGE CLOSED

### TURN MOVEMENT 1 (2045)

**\*\*DHV TURN MOVEMENT FORECASTS SHOULD NOT BE USED FOR SIGNAL TIMING OR WARRANT ANALYSIS\*\***

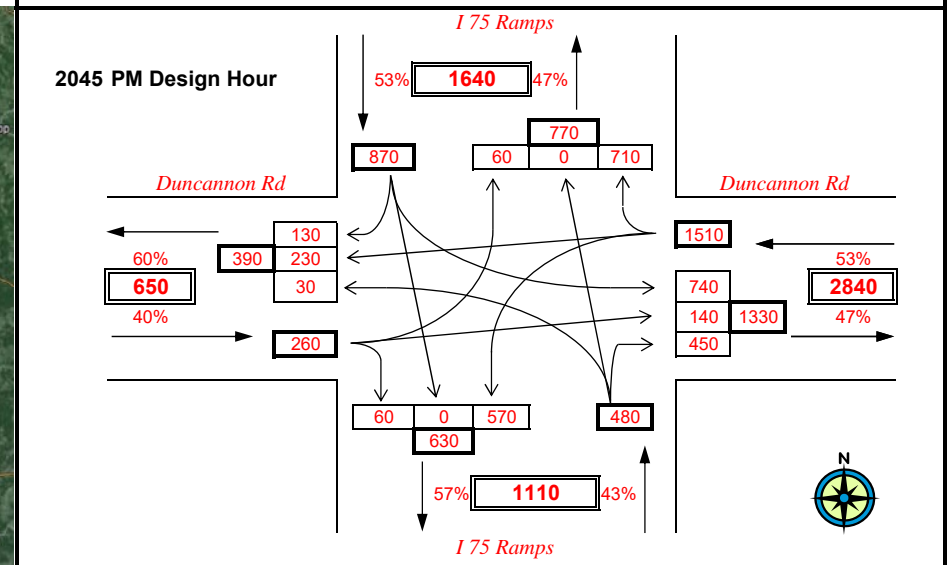
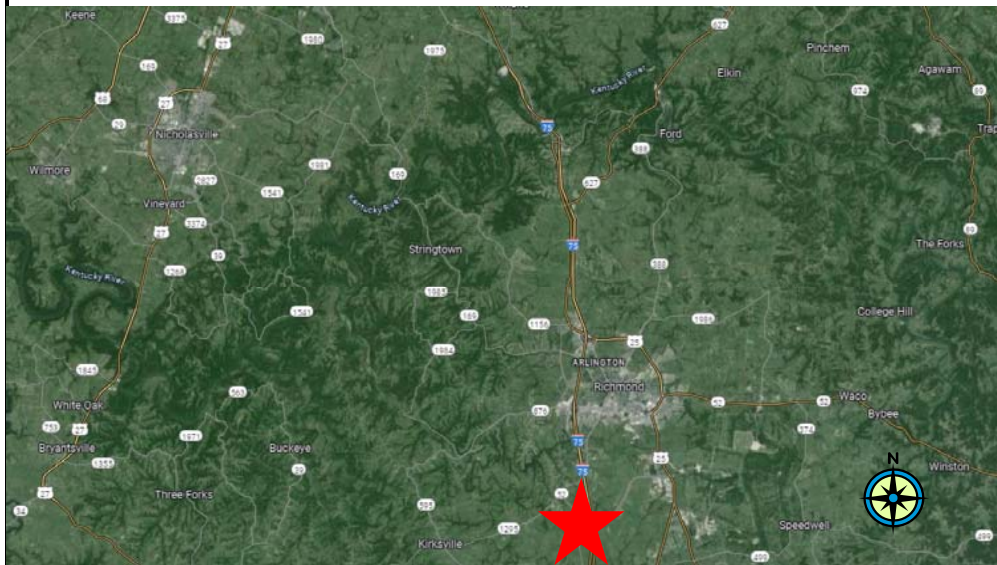
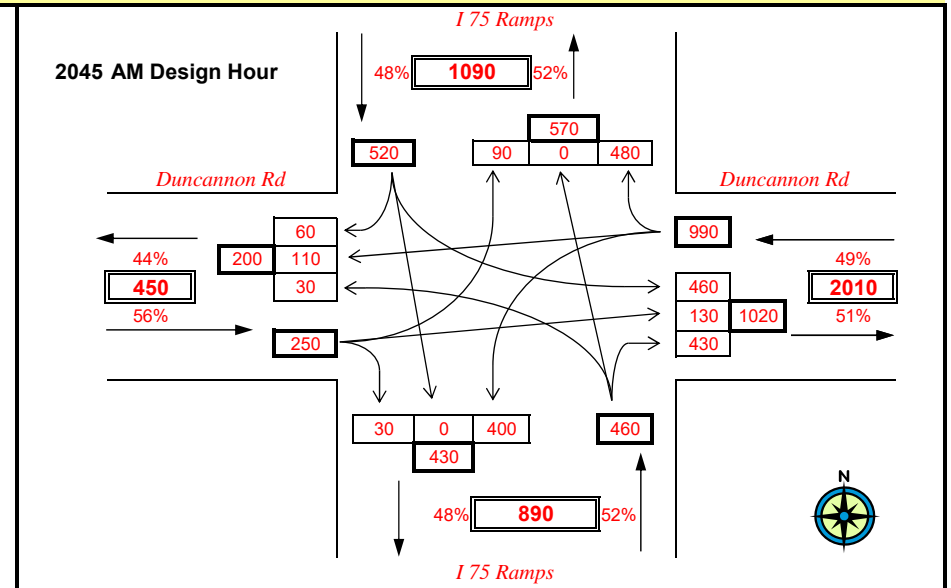
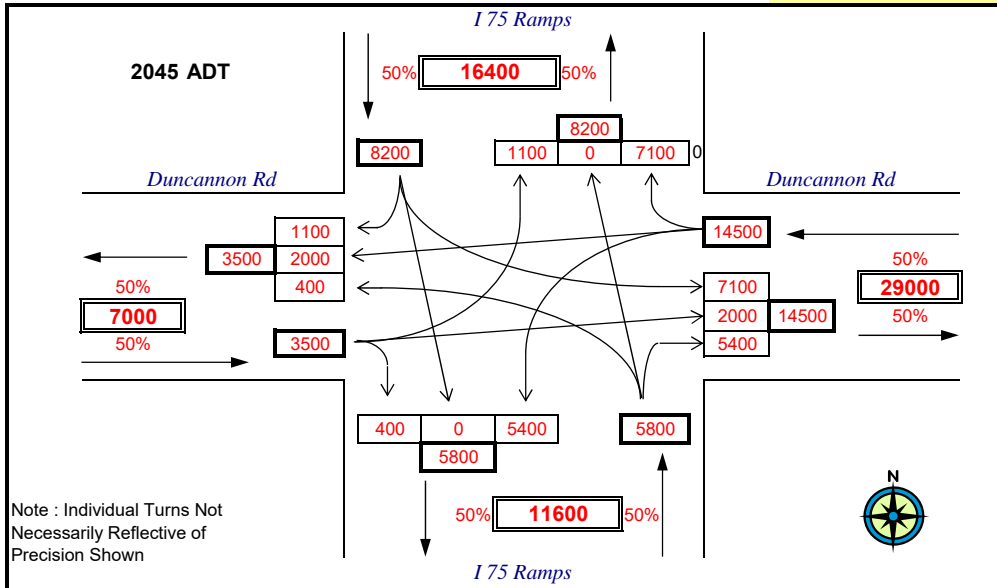

PROJECT: Clays Ferry Bridge Closure  
 ITEM NUMBER: 0  
 MARS NUMBER: 0  
 REQUEST DATE: Saturday, January 0, 1900  
 ANALYST: 0  
 YEAR: 2045 ADT and Design Hour Volumes  
 INTERSECTION: KY 627 & I 75 Ramps

## 2045 NO BUILD BRIDGE CLOSED

### TURN MOVEMENT 2 (2045)

**\*\*DHV TURN MOVEMENT FORECASTS SHOULD NOT BE USED FOR SIGNAL TIMING OR WARRANT ANALYSIS**

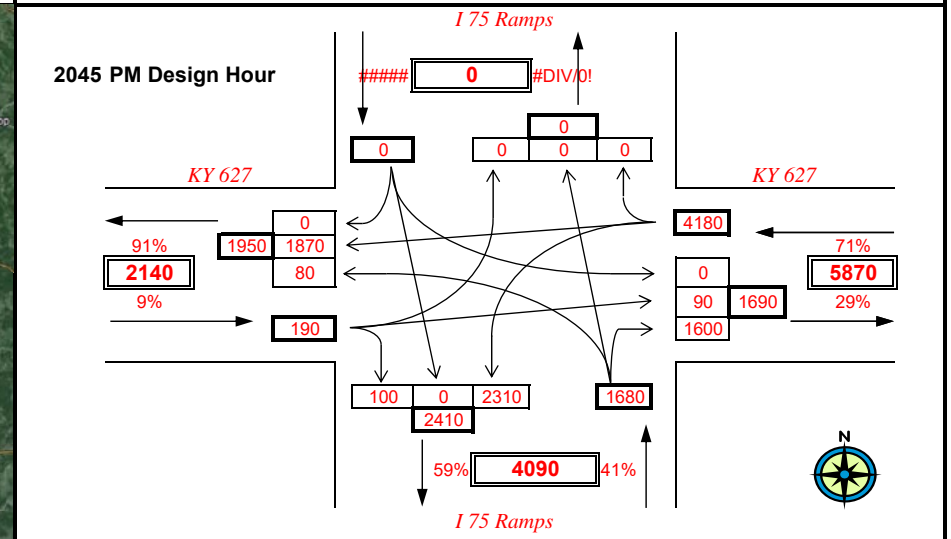
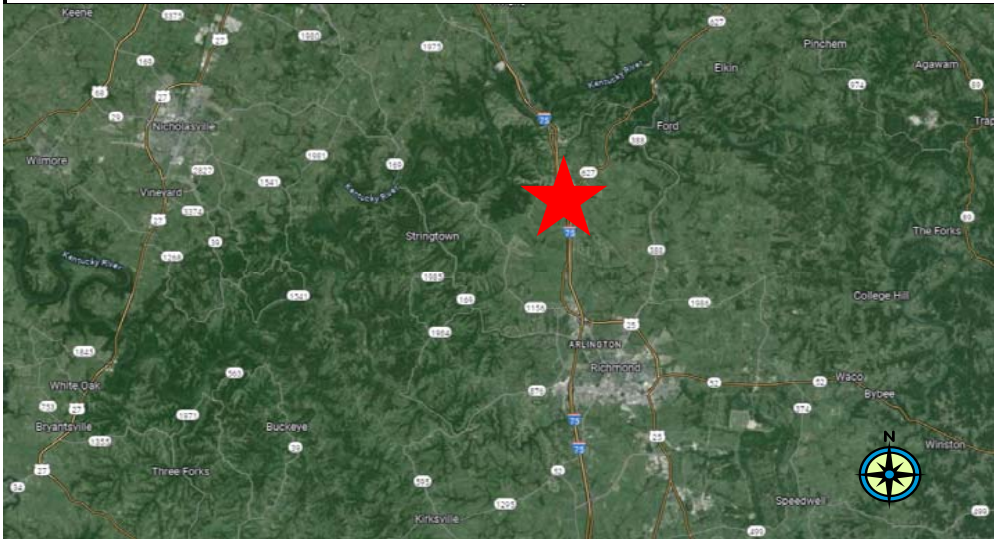
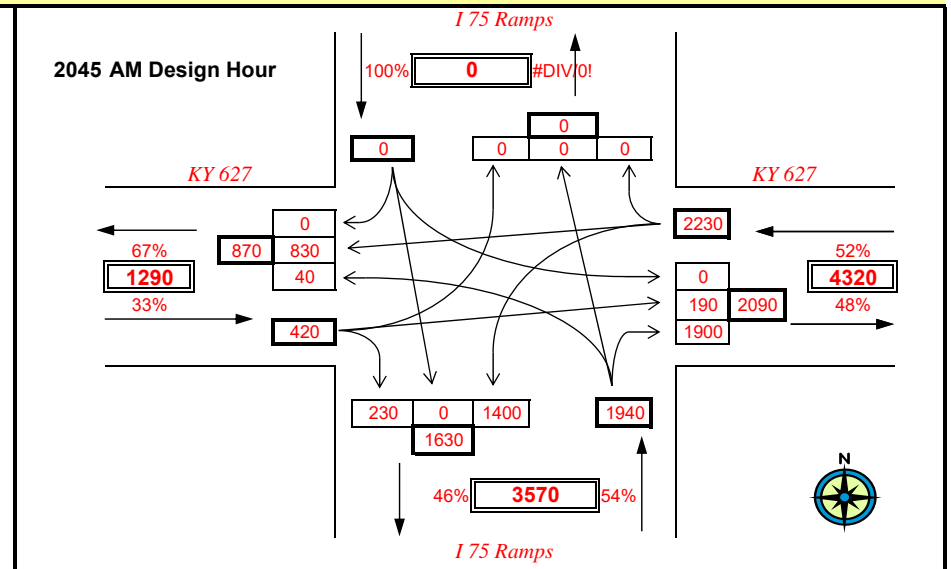
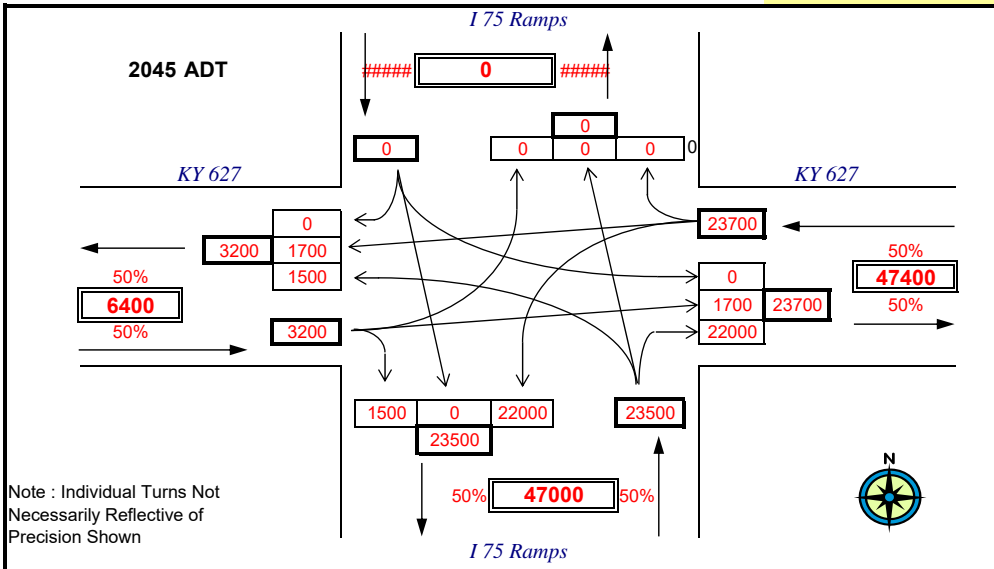

PROJECT: Clays Ferry Bridge Closure Phase 2  
 ITEM NUMBER: 0  
 MARS NUMBER: 0  
 REQUEST DATE: Saturday, January 0, 1900  
 ANALYST: 0  
 YEAR: 2045 ADT and Design Hour Volumes  
 INTERSECTION: I 75 Ramps & US 25

## 2045 NO BUILD BRIDGE CLOSED

### TURN MOVEMENT 3 (2045)

**\*\*DHV TURN MOVEMENT FORECASTS SHOULD NOT BE USED FOR SIGNAL TIMING OR WARRANT ANALYSIS**

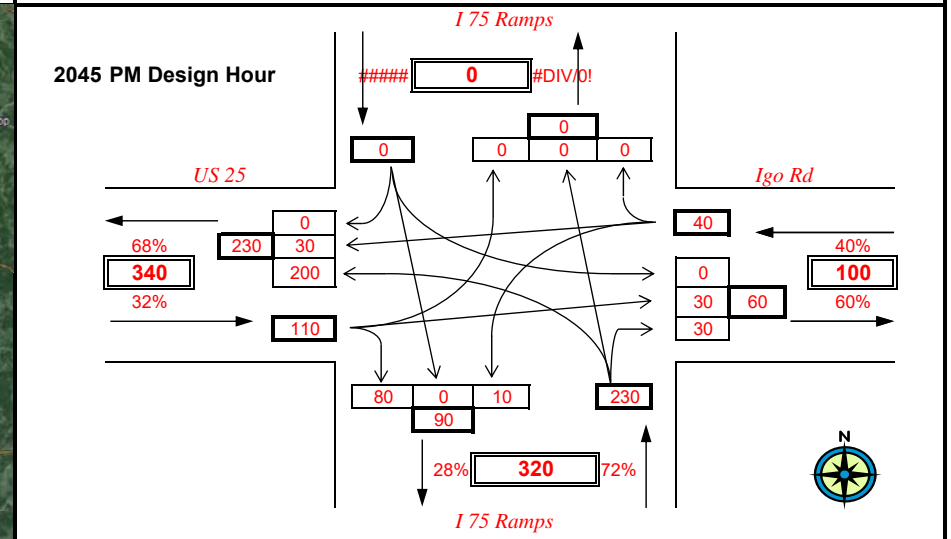
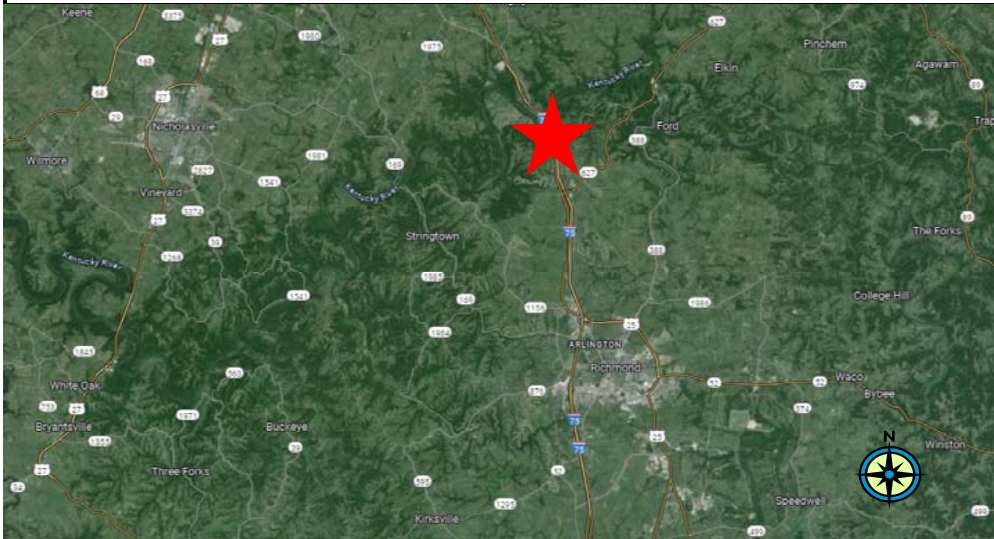
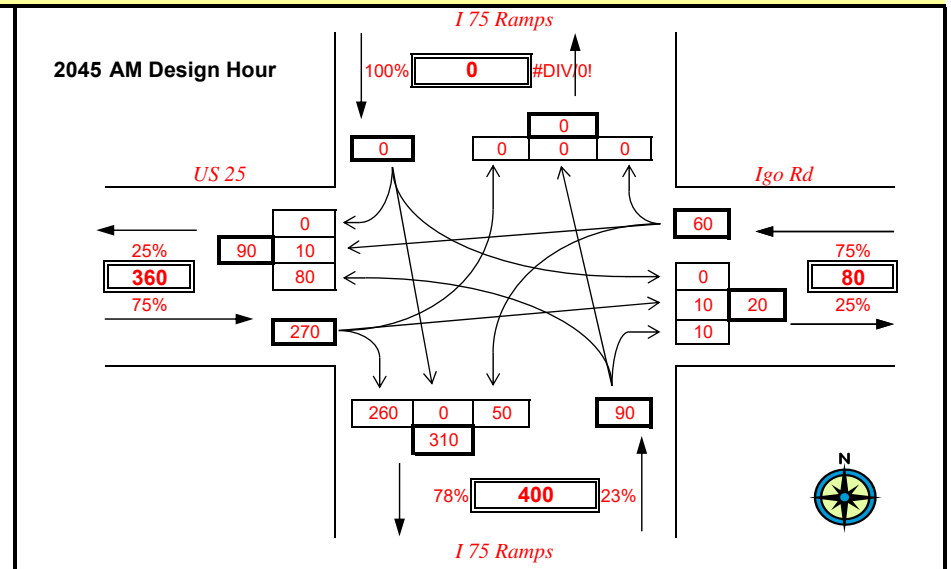
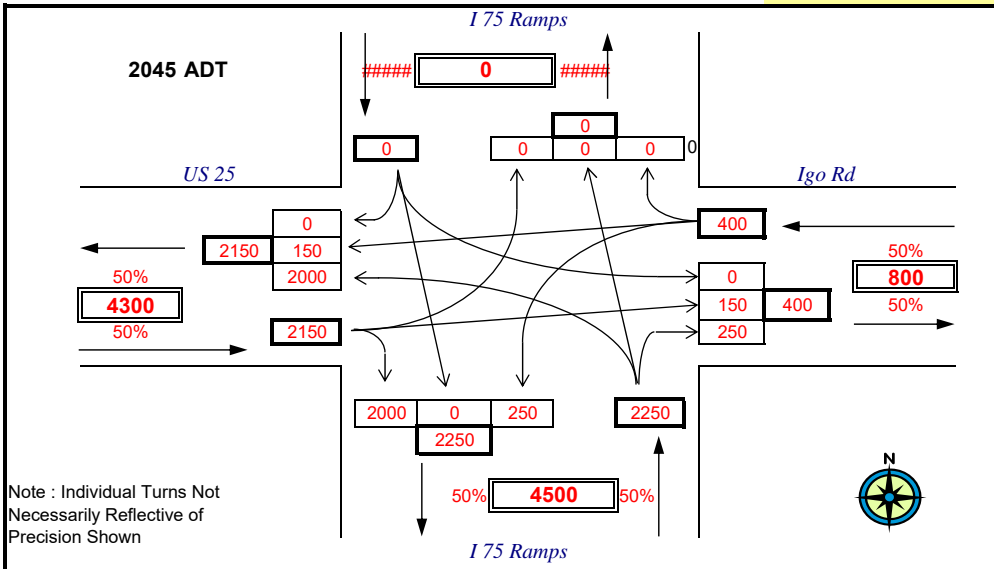



PROJECT: Clays Ferry Bridge Closure  
 ITEM NUMBER: 0  
 MARS NUMBER: 0  
 REQUEST DATE: Saturday, January 0, 1900  
 ANALYST: 0  
 YEAR: 2045 ADT and Design Hour Volumes  
 INTERSECTION: US 25 N & I 75 Ramps

## 2045 NO BUILD BRIDGE CLOSED

### TURN MOVEMENT 4 (2045)

**\*\*DHV TURN MOVEMENT FORECASTS SHOULD NOT BE USED FOR SIGNAL TIMING OR WARRANT ANALYSIS**

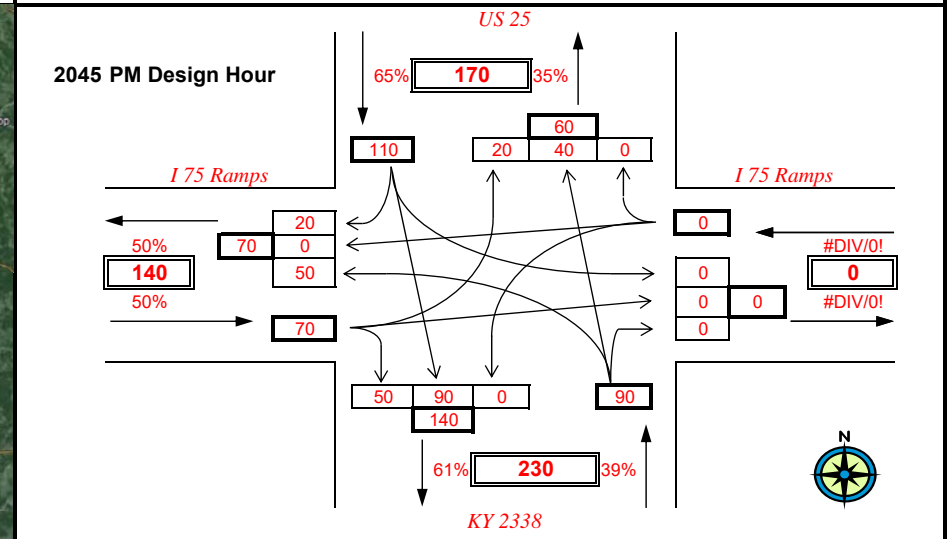
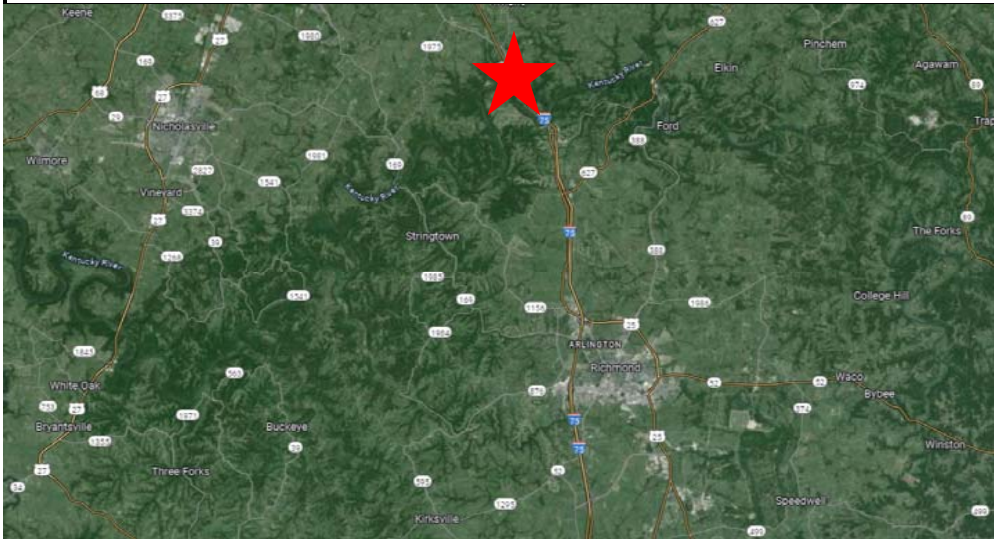
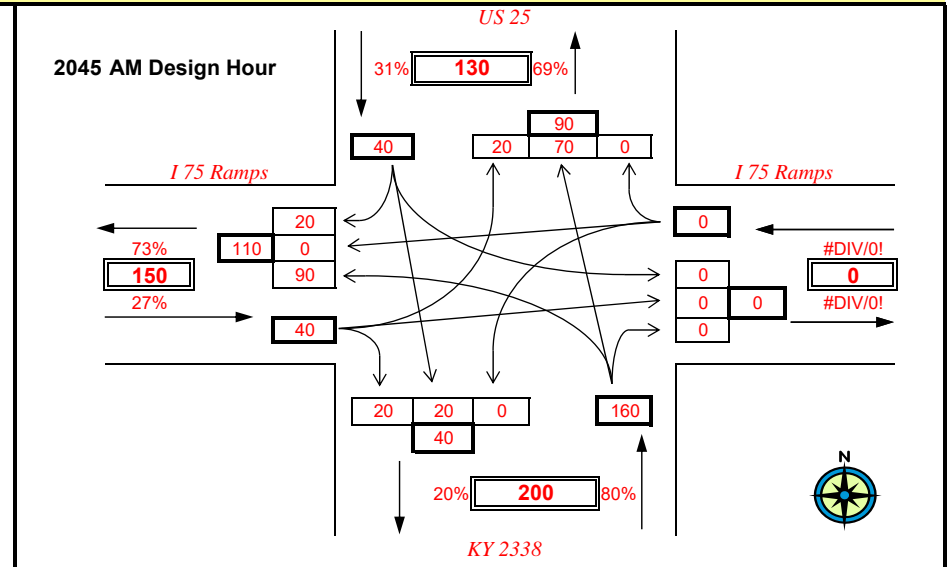
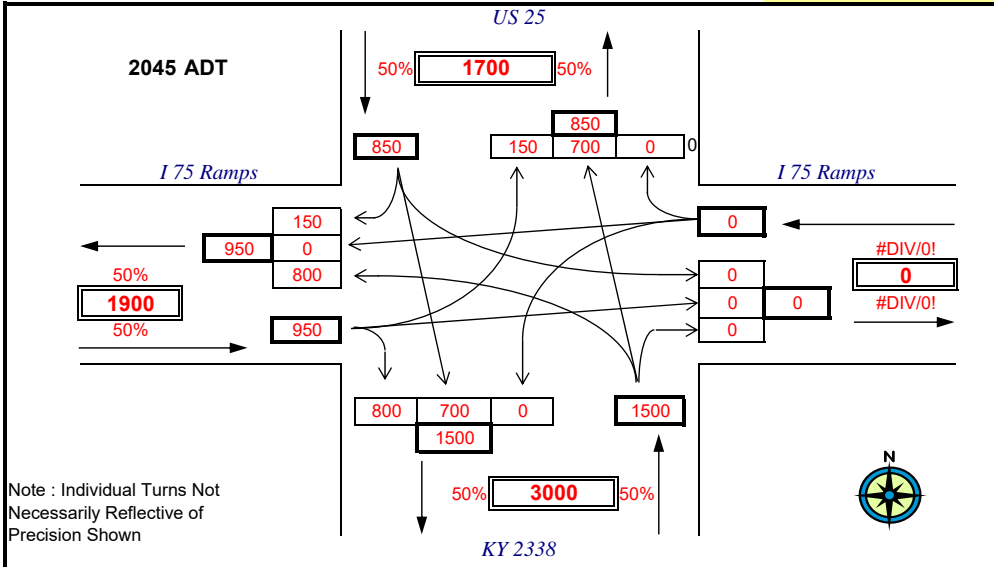

# APPENDIX D

BUILD SOUTHERN CONNECTOR – BRIDGE CLOSED TURNING  
MOVEMENT FORECASTS

PROJECT: Clays Ferry Bridge Closure

ITEM NUMBER: 0

MARS NUMBER: 0

REQUEST DATE: Saturday, January 0, 1900

ANALYST: 0

YEAR: 2045 ADT and Design Hour Volumes

INTERSECTION: I75 & Duncannon Interchange

2045 BRIDGE CLOSED BUILD SOUTH OPTION

### TURN MOVEMENT 1 (2045)

**\*\*DHV TURN MOVEMENT FORECASTS SHOULD NOT BE USED FOR SIGNAL TIMING OR WARRANT ANALYSIS**

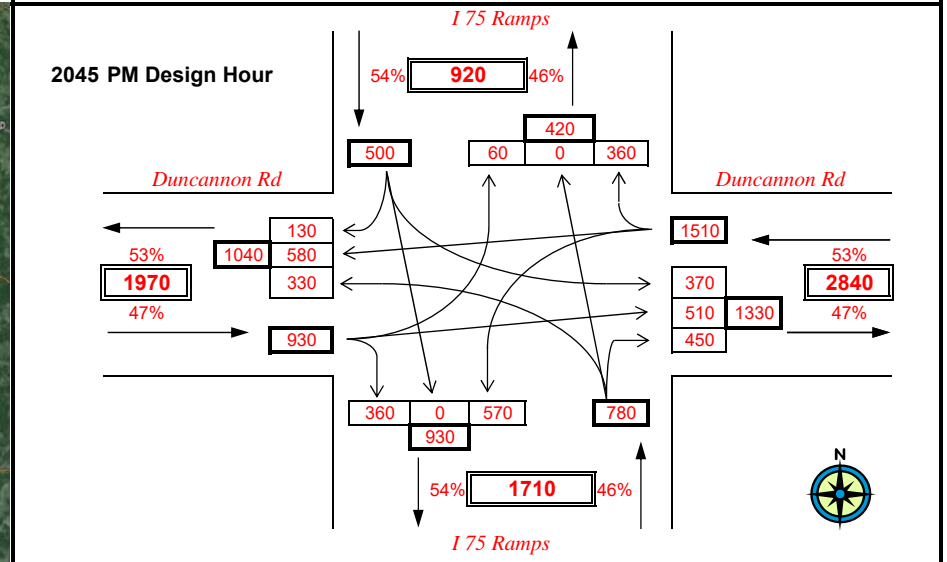
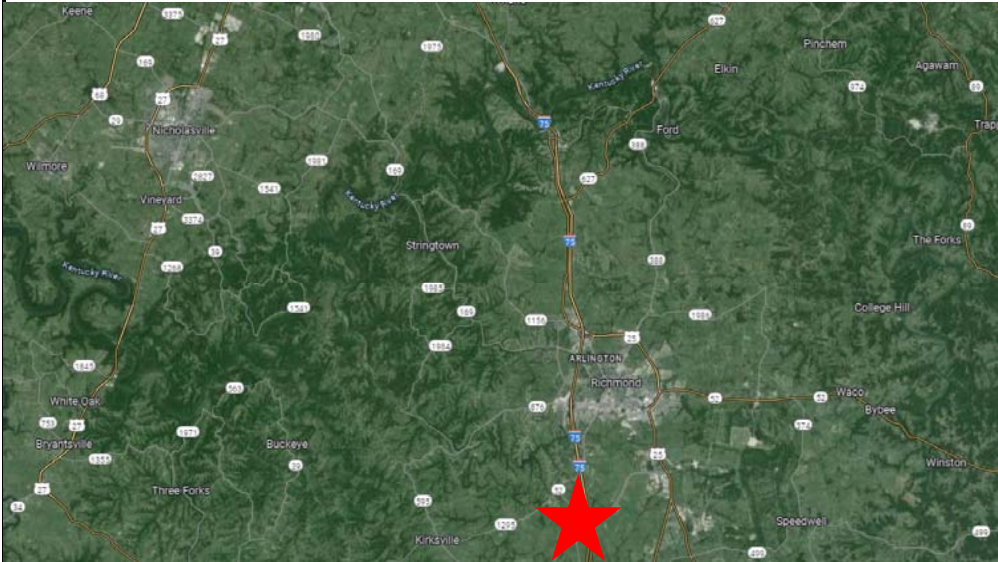
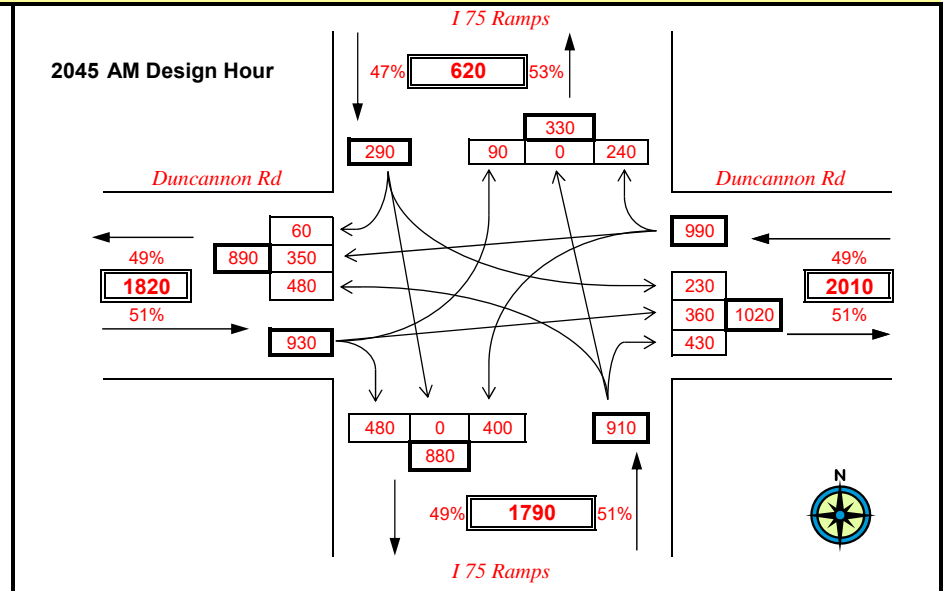
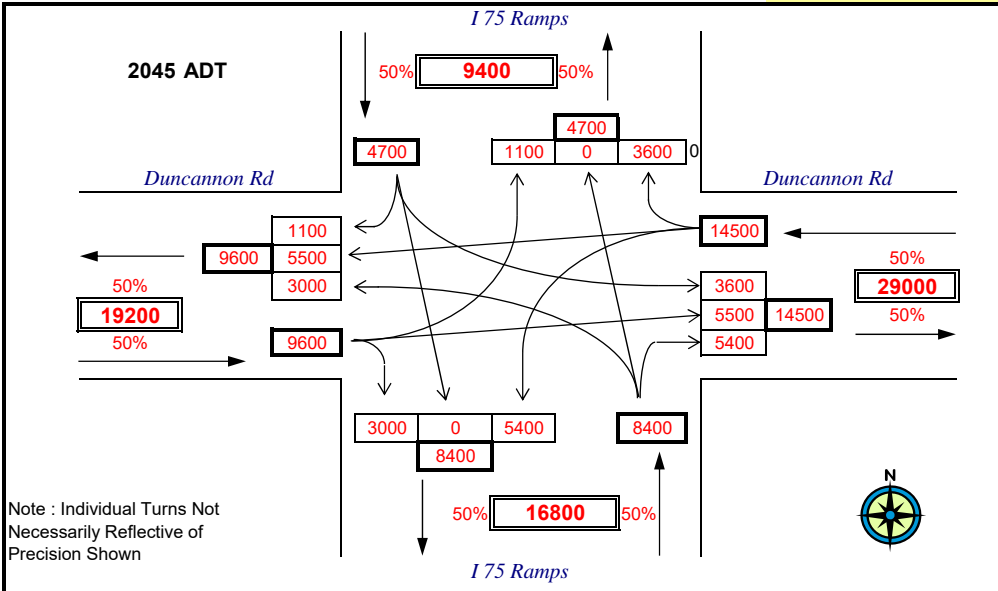

# APPENDIX E

BUILD CENTRAL CONNECTOR – BRIDGE CLOSED TURNING  
MOVEMENT FORECASTS

PROJECT: Clays Ferry Bridge Closure  
 ITEM NUMBER: 0  
 MARS NUMBER: 0  
 REQUEST DATE: Saturday, January 0, 1900  
 ANALYST: 0  
 YEAR: 2045 ADT and Design Hour Volumes  
 INTERSECTION: KY 627 & I 75 Ramps

# 2045 BRIDGE CLOSED BUILD TATES CREEK

## TURN MOVEMENT 2 (2045)

**\*\*DHV TURN MOVEMENT FORECASTS SHOULD NOT BE USED FOR SIGNAL TIMING OR WARRANT ANALYSIS\*\***

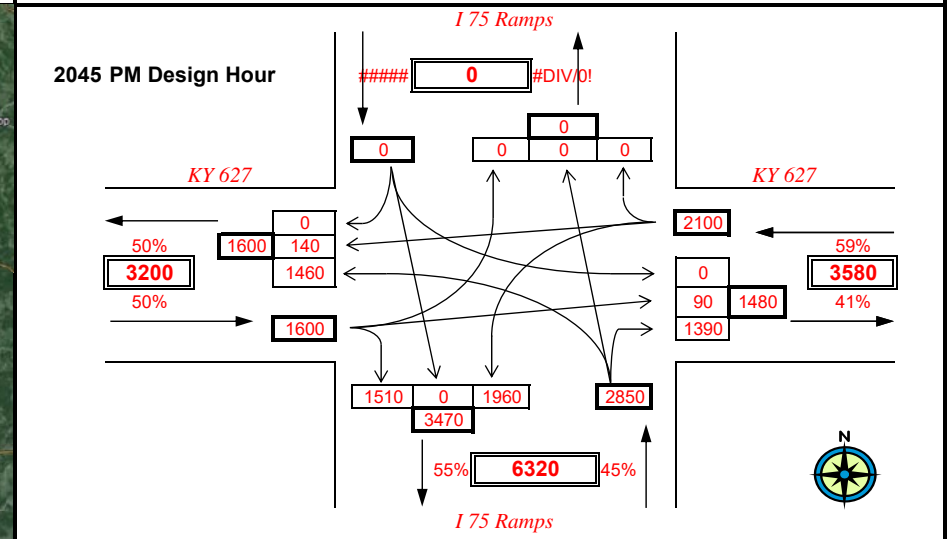
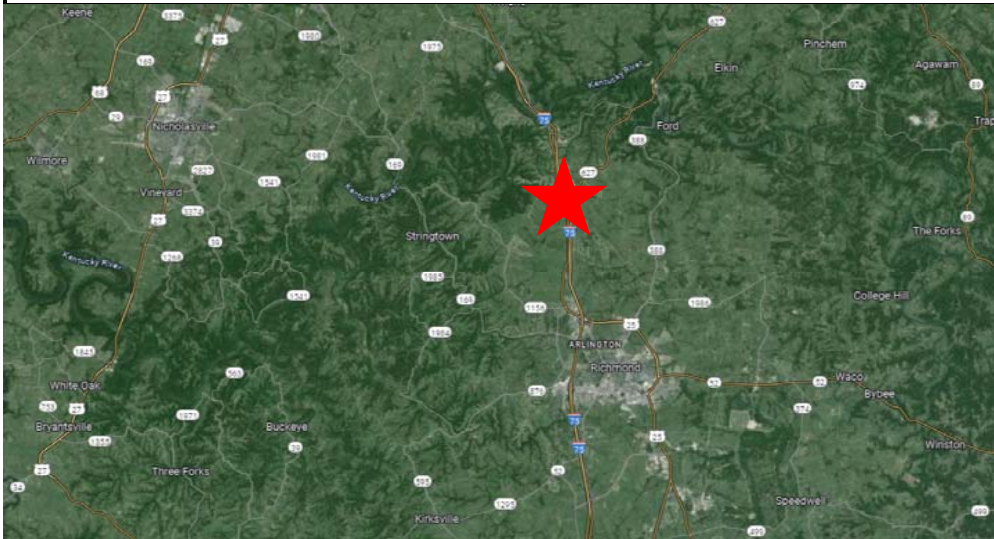
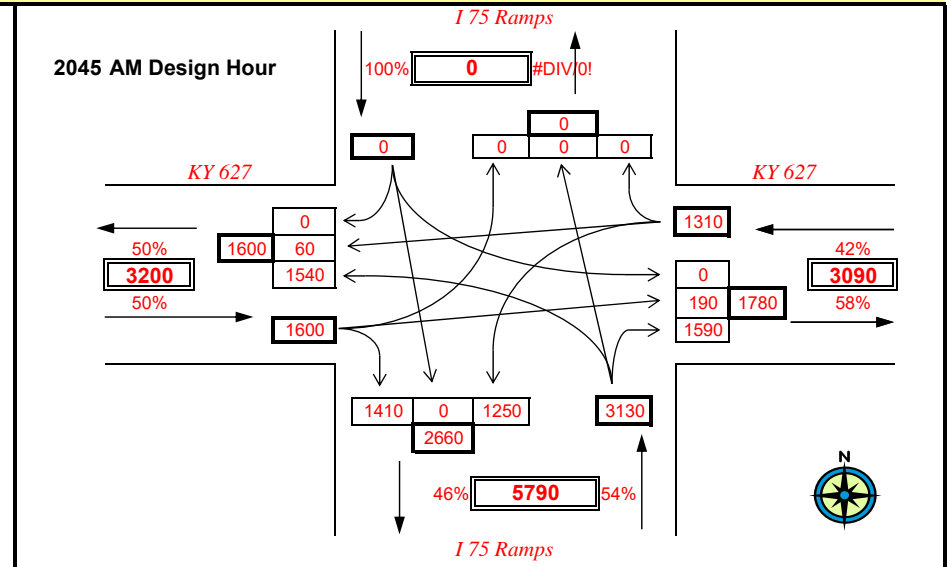
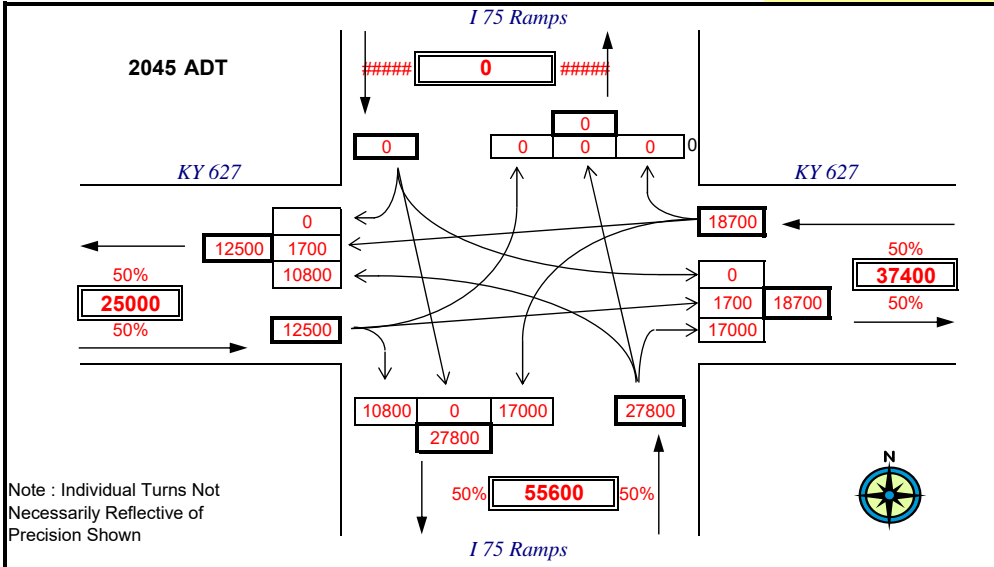

# APPENDIX E

BUILD ADJACENT BRIDGE – BRIDGE CLOSED TURNING  
MOVEMENT FORECASTS

PROJECT: Clays Ferry Bridge Closure  
 ITEM NUMBER: 0  
 MARS NUMBER: 0  
 REQUEST DATE: Saturday, January 0, 1900  
 ANALYST: 0  
 YEAR: 2045 ADT and Design Hour Volumes  
 INTERSECTION: KY 627 & I 75 Ramps

# 2045 BUILD ADJACENT BRIDGE BRIDGE CLOSED

## TURN MOVEMENT 2 (2045)

**\*\*DHV TURN MOVEMENT FORECASTS SHOULD NOT BE USED FOR SIGNAL TIMING OR WARRANT ANALYSIS\*\***

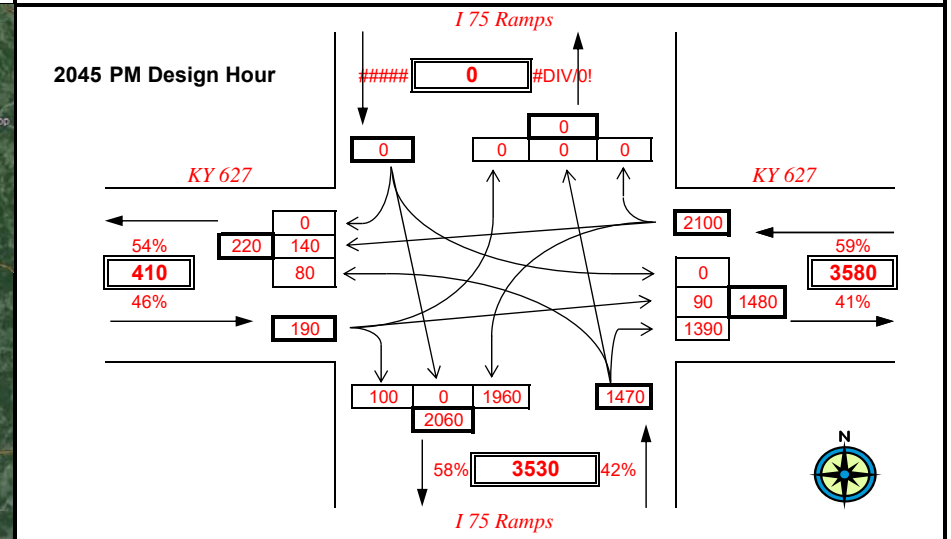
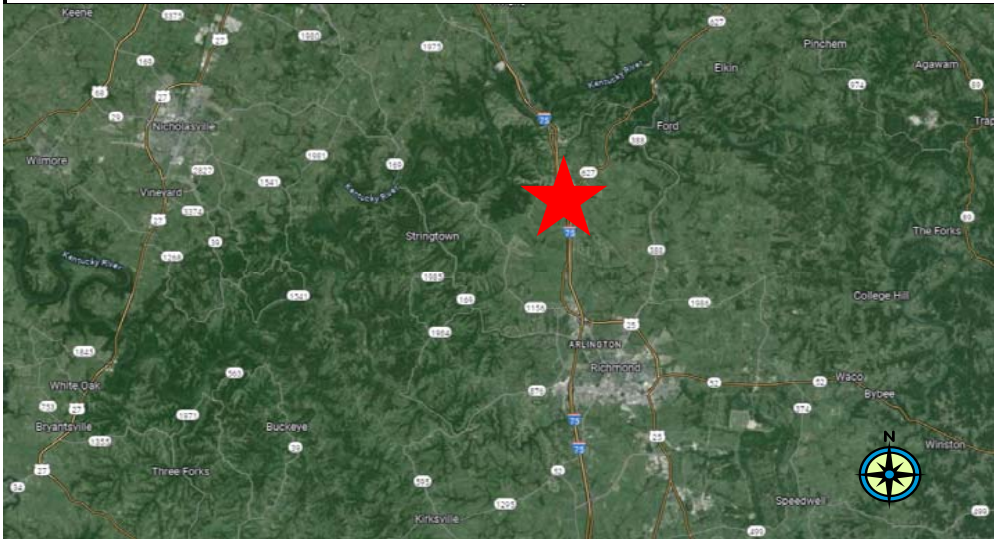
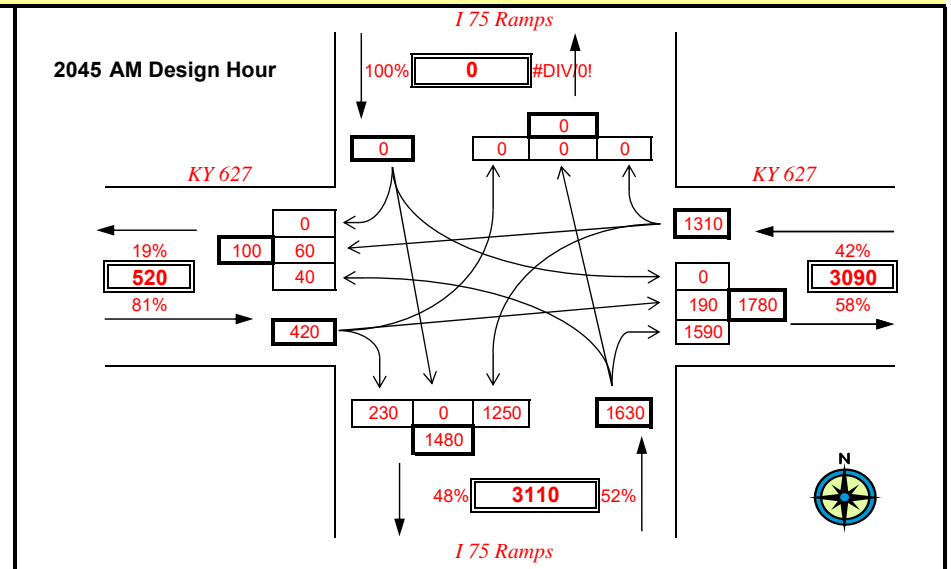
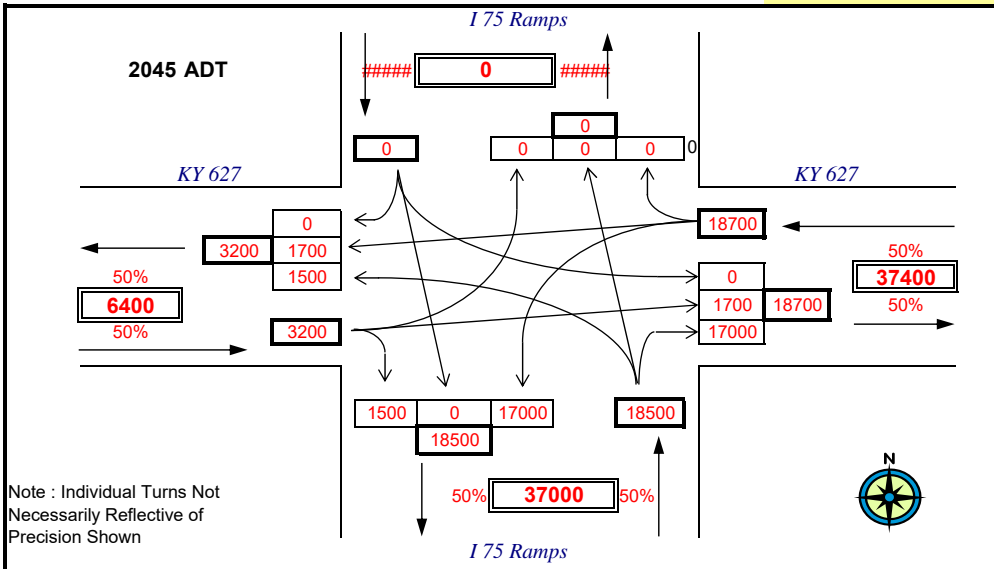

PROJECT: Clays Ferry Bridge Closure Phase 2  
 ITEM NUMBER: 0  
 MARS NUMBER: 0  
 REQUEST DATE: Saturday, January 0, 1900  
 ANALYST: 0  
 YEAR: 2045 ADT and Design Hour Volumes  
 INTERSECTION: I 75 Ramps & US 25

# 2045 BUILD ADJACENT BRIDGE BRIDGE CLOSED

## TURN MOVEMENT 3 (2045)

**\*\*DHV TURN MOVEMENT FORECASTS SHOULD NOT BE USED FOR SIGNAL TIMING OR WARRANT ANALYSIS\*\***

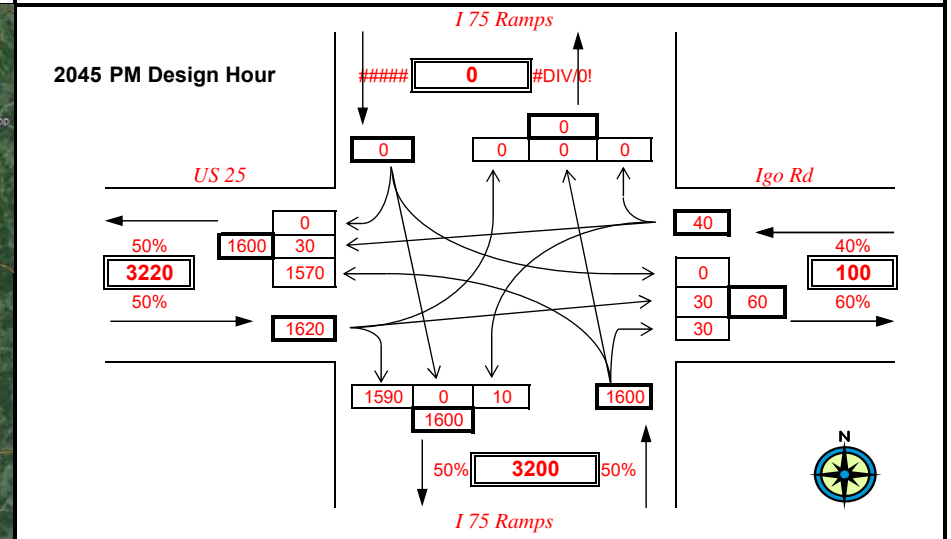
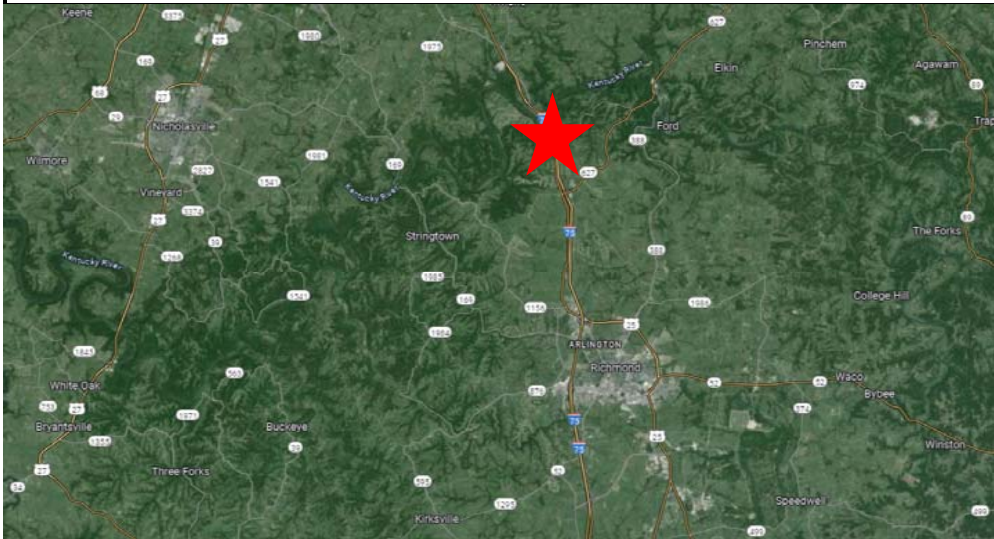
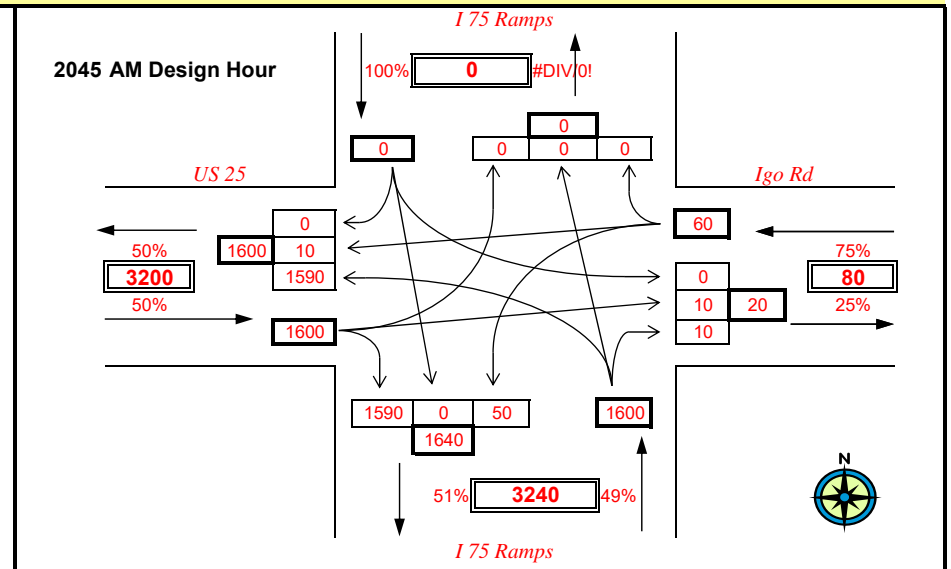
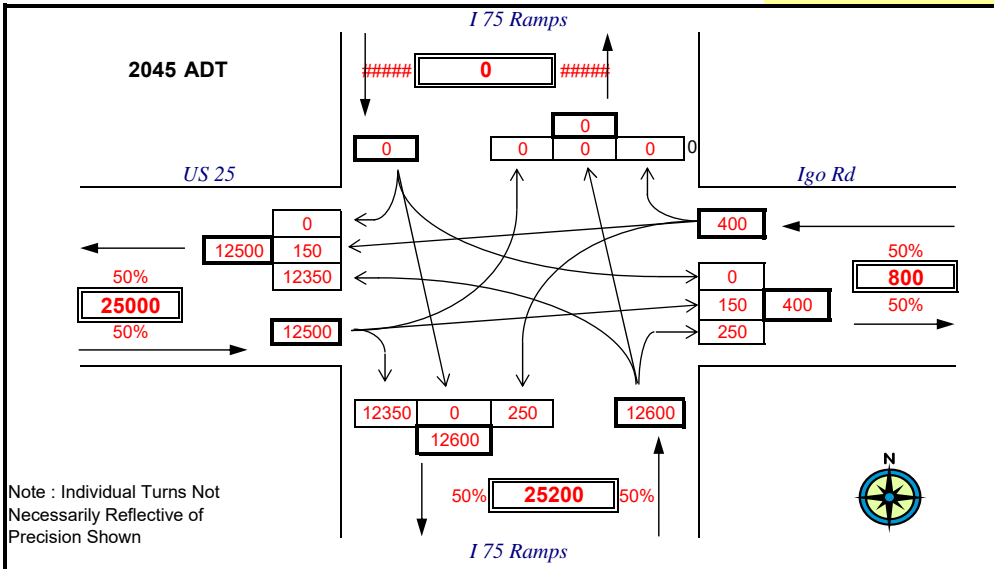



PROJECT: Clays Ferry Bridge Closure  
 ITEM NUMBER: 0  
 MARS NUMBER: 0  
 REQUEST DATE: Saturday, January 0, 1900  
 ANALYST: 0  
 YEAR: 2045 ADT and Design Hour Volumes  
 INTERSECTION: US 25 N & I 75 Ramps

# 2045 BUILD ADJACENT BRIDGE BRIDGE CLOSED

## TURN MOVEMENT 4 (2045)

**\*\*DHV TURN MOVEMENT FORECASTS SHOULD NOT BE USED FOR SIGNAL TIMING OR WARRANT ANALYSIS**

